



Profit from the Eagle Advantage®

# Specification Sheet

## Short Form Specifications

All stainless steel type 304 bench frame. 22" or 28" deep. 35" Standing Height and 29-1/8" Sitting Height. Widths available from 22" to 70". 2" square legs with leveling bolt and leg shoes. Heavy gauge corner angles are welded to the legs and tapped for bolting on 5" high aprons. One 3" drawer assembly with 4" wire pull and full extension ball bearing slides. Designed and tested to the SEFA 8 Metal Casework recommended practices.

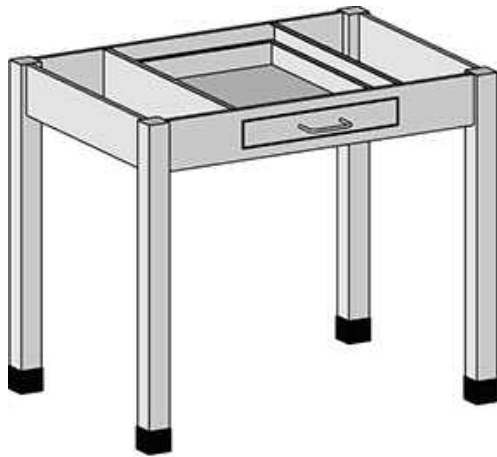

Item No.:	_____
Project No.:	_____
S.I.S. No.:	_____

## Bench Frames with One Drawer

### MODELS:

- |  |  |  |
|--|--|--|
| <input type="checkbox"/> SSC-HT1D-2424 | <input type="checkbox"/> SSC-HT1D-3042 | <input type="checkbox"/> SSC-ST1D-2466 |
| <input type="checkbox"/> SSC-HT1D-2430 | <input type="checkbox"/> SSC-HT1D-3048 | <input type="checkbox"/> SSC-ST1D-2472 |
| <input type="checkbox"/> SSC-HT1D-2436 | <input type="checkbox"/> SSC-HT1D-3060 | <input type="checkbox"/> SSC-ST1D-3024 |
| <input type="checkbox"/> SSC-HT1D-2442 | <input type="checkbox"/> SSC-HT1D-3066 | <input type="checkbox"/> SSC-ST1D-3030 |
| <input type="checkbox"/> SSC-HT1D-2448 | <input type="checkbox"/> SSC-HT1D-3072 | <input type="checkbox"/> SSC-ST1D-3036 |
| <input type="checkbox"/> SSC-HT1D-2460 | <input type="checkbox"/> SSC-ST1D-2424 | <input type="checkbox"/> SSC-ST1D-3042 |
| <input type="checkbox"/> SSC-HT1D-2466 | <input type="checkbox"/> SSC-ST1D-2430 | <input type="checkbox"/> SSC-ST1D-3048 |
| <input type="checkbox"/> SSC-HT1D-2472 | <input type="checkbox"/> SSC-ST1D-2436 | <input type="checkbox"/> SSC-ST1D-3060 |
| <input type="checkbox"/> SSC-HT1D-3024 | <input type="checkbox"/> SSC-ST1D-2442 | <input type="checkbox"/> SSC-ST1D-3066 |
| <input type="checkbox"/> SSC-HT1D-3030 | <input type="checkbox"/> SSC-ST1D-2448 | <input type="checkbox"/> SSC-ST1D-3072 |
| <input type="checkbox"/> SSC-HT1D-3036 | <input type="checkbox"/> SSC-ST1D-2460 |  |

### Design and Construction Features

- Type 304 stainless steel construction.
- Available in 35" (889mm) Standing Height and 29 1/8" (740mm) Sitting Height.
- 22" or 28" (559 or 711mm) depth.
- 3" (76mm)-high drawer assembly with 4" (102mm) wire pull handle.
- Frame assembly features 5" (127mm)-high apron on all four sides.
- Full-height 2" (51mm)-square tubular legs, with leveling mount inserts and leg shoes.
- Shipped knocked down.

### Options / Accessories

- Drawer locks
- Soft-close drawer slides
- Custom drawer pulls
- Custom sizes

### Certifications / Approvals



SEFA 8 Metal Casework

### EAGLE GROUP

100 Industrial Boulevard  
Clayton, DE 19938-8903 USA

Phone: 302-653-3000 • 800-441-8440

Fax: 302-653-2065

www.eaglegrp.com • www.eaglemhc.com

For custom configuration or fabrication needs, contact our SpecFAB® Division.

Phone: 302-653-3000 • Fax: 302-653-2065 • e-mail: quotes@eaglegrp.com

EG03.05B Rev. 05/21

Spec sheets available for viewing, printing or downloading from our online literature library at [www.eaglegrp.com](http://www.eaglegrp.com)

Eagle Foodservice Equipment, Eagle MHC, and SpecFAB® are divisions of Eagle Group. ©2021 by the Eagle Group



Item No.: \_\_\_\_\_  
 Project No.: \_\_\_\_\_  
 S.I.S. No.: \_\_\_\_\_

## Bench Frames with One Drawer

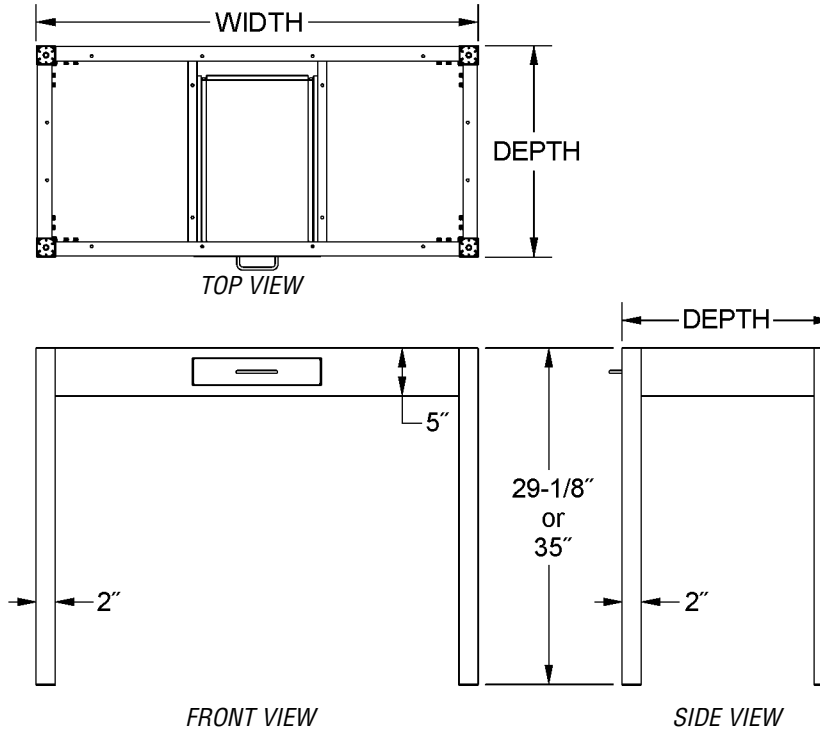

depth*		width*		35" Standing Height			29 1/8" Sitting Height		
in	mm	in	mm	weight lbs.	weight kg	model #	weight lbs.	weight kg	model #
22"	559	22"	559	50	22.7	SSC-HT1D-2424	48	21.8	SSC-ST1D-2424
22"	559	28"	711	55	24.9	SSC-HT1D-2430	53	24.0	SSC-ST1D-2430
22"	559	34"	864	60	27.2	SSC-HT1D-2436	58	26.3	SSC-ST1D-2436
22"	559	40"	1016	65	29.5	SSC-HT1D-2442	63	28.6	SSC-ST1D-2442
22"	559	46"	1168	70	31.7	SSC-HT1D-2448	68	30.8	SSC-ST1D-2448
22"	559	58"	1473	78	35.4	SSC-HT1D-2460	76	34.5	SSC-ST1D-2460
22"	559	64"	1626	84	38.1	SSC-HT1D-2466	82	37.2	SSC-ST1D-2466
22"	559	70"	1778	90	40.8	SSC-HT1D-2472	88	39.9	SSC-ST1D-2472
28"	711	22"	559	55	24.9	SSC-HT1D-3024	53	24.0	SSC-ST1D-3024
28"	711	28"	711	58	26.3	SSC-HT1D-3030	56	25.4	SSC-ST1D-3030
28"	711	34"	864	65	29.5	SSC-HT1D-3036	63	28.6	SSC-ST1D-3036
28"	711	40"	1016	70	31.7	SSC-HT1D-3042	68	30.8	SSC-ST1D-3042
28"	711	46"	1168	75	34.0	SSC-HT1D-3048	73	33.1	SSC-ST1D-3048
28"	711	58"	1473	84	38.1	SSC-HT1D-3060	82	37.2	SSC-ST1D-3060
28"	711	64"	1626	91	41.3	SSC-HT1D-3066	89	40.4	SSC-ST1D-3066
28"	711	70"	1778	98	44.4	SSC-HT1D-3072	96	43.5	SSC-ST1D-3072

\* Allows 1" (25mm) overhang from each side of table frame to be fitted for top.

**EAGLE GROUP**  
 100 Industrial Boulevard, Clayton, DE 19938-8903 USA  
 Phone: 302-653-3000 or 800-441-8440 • Fax: 302-653-2065  
 www.eaglegrp.com • www.eaglehmc.com

Printed in U.S.A.  
 ©2021 by Eagle Group  
 Rev. 05/21

Spec sheets available for viewing, printing or downloading from our online literature library at [www.eaglegrp.com](http://www.eaglegrp.com)

Although every attempt has been made to ensure the accuracy of the information provided, we cannot be held responsible for typographical or printing errors. Information and specifications are subject to change without notice. Please confirm at time of order.