

LifeStor® Master Trak®

ASSEMBLY INSTRUCTIONS

CAUTION

INSPECT CONTENTS IMMEDIATELY AND FILE CLAIM WITH DELIVERING CARRIER FOR ANY DAMAGE. **SAVE YOUR BOX AND ALL PACKING MATERIALS.** YOU ARE RESPONSIBLE FOR DAMAGE TO YOUR UNIT IF RETURNED IMPROPERLY PACKED.



Parts List

#	qty	description
Stationary Units		
#1	4	Stationary unit posts
#2	4	Foot plates
Mobile Units		
#3	4	Bearing assemblies
#4	4	Mobile unit posts
#5	1	Dolly frame
#6	4	Bolts (for mounting posts to dolly frame)
Overhead Track Units		
#7	(see chart below)	Stainless steel connectors
#8	(see chart below)	Aluminum top tracks

#	qty	description
Hardware (with stationary & mobile units)		
#9	4	Hex bolts
Hardware (with overhead track units)		
#10	(see chart below)	Acorn nuts
#11	(see chart below)	Lock washers
#12	(see chart below)	Screws

Overhead Track Units—Quantities of Components

overhead track length	# of screws, washers, & nuts	# of stainless steel connectors	# of aluminum top tracks
6'-9'	0	0	2
10'-18'	12	2	4
19'-21'	24	4	6

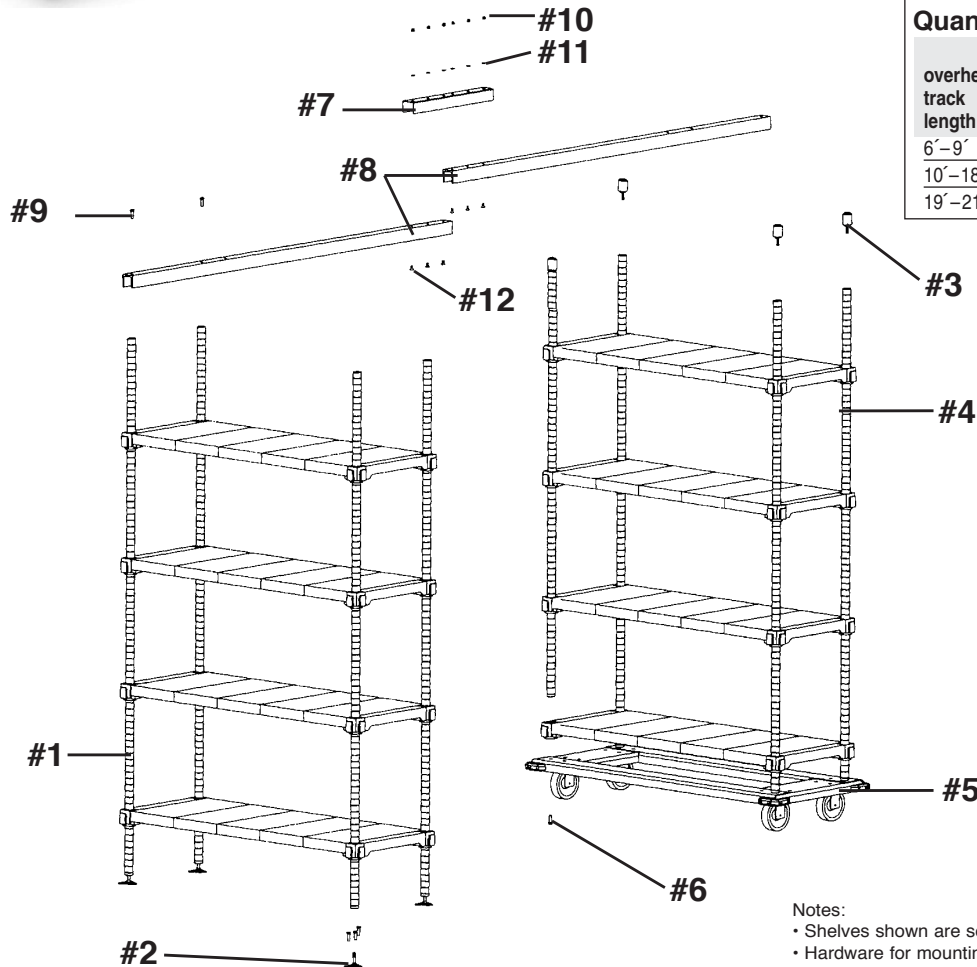

Notes:
 • Shelves shown are sold separately.
 • Hardware for mounting stationary units to floor not included.

(continued on Page 2)

EG9814 Revised 08/14

Assemble stationary end units.

1. Locate stationary end unit posts. Both ends of the post will have a pressed-in threaded insert (see *Figure 1*). The mobile unit posts will have a threaded insert in the top. Four (4) posts are required for each unit.
2. Screw adjustable flat foot plate into bottom of the stationary post (see *Figure 2*).
3. Mount shelving per instructions.

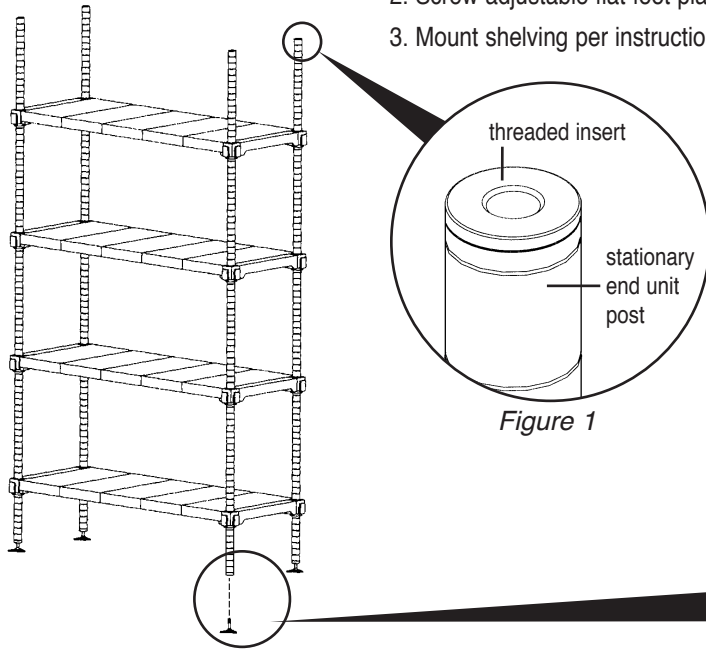

Figure 1

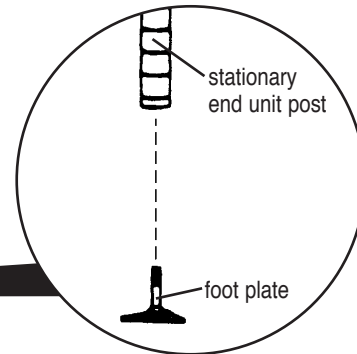

Figure 2

Assemble overhead track units.

Note: Tracks 10' and longer will require additional assembly of stainless steel connectors to the aluminum track pieces. For track units up to 9' long, ignore #1 & 2 and go to #3.

1. Lay track on flat surface. Locate the end of the track that has only three holes. This will be the joining end. Butt both joining ends together and place the stainless steel connector on top of the track. Align holes, and screw the pieces together as shown in *Figure 3* using screw, lock washer, and acorn nut.
2. Once tightened, check to see if screw heads are properly countersunk as shown in *Figure 4*.
3. Place overhead tracks off to the side until the mobile units are installed and in place.

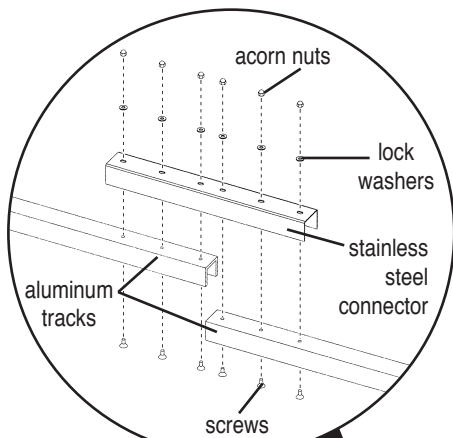

Figure 3

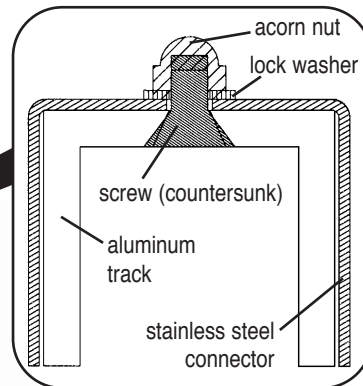

Figure 4

(continued on Page 3)

Assemble mobile units.

1. Install each mobile unit post onto each corner of dolly frame with bolt as shown in *Figure 5*.
2. Bolt a roller assembly to the top threaded insert of each post as shown in *Figure 6*.
3. Mount shelving per instructions.

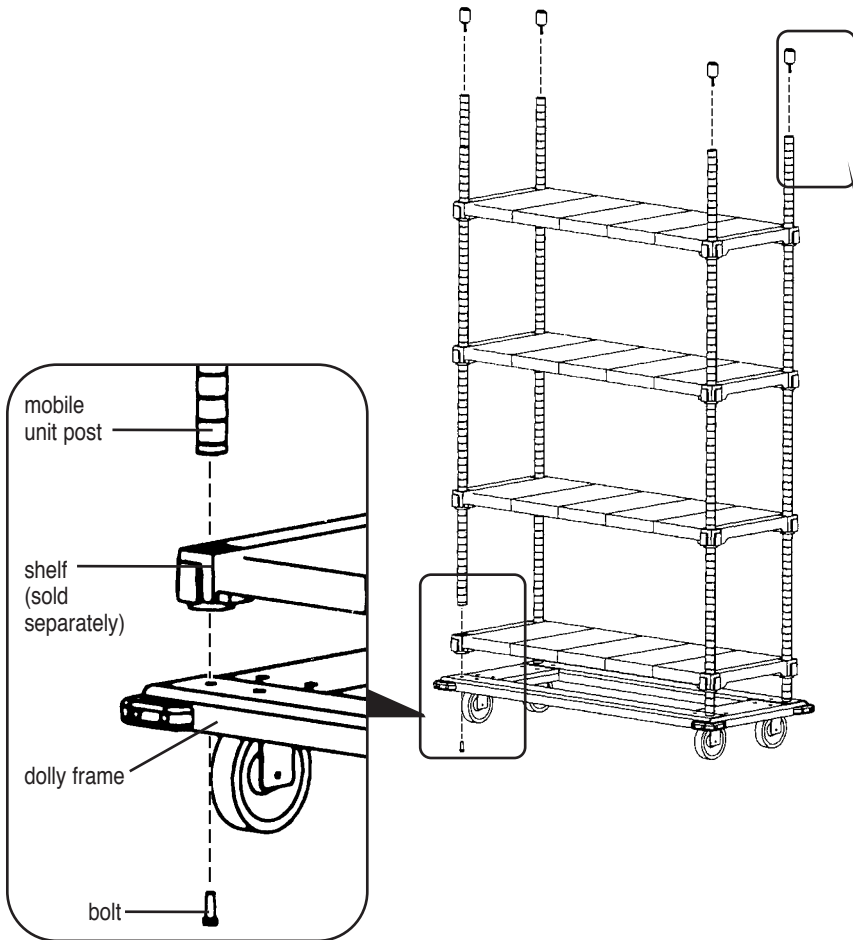

Figure 5

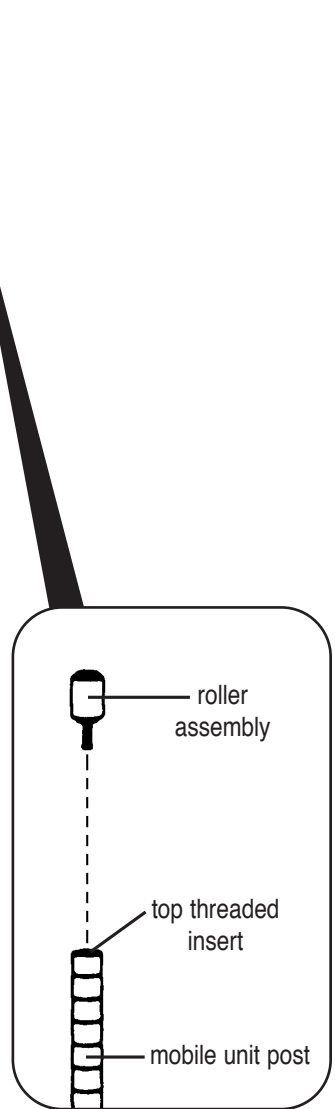
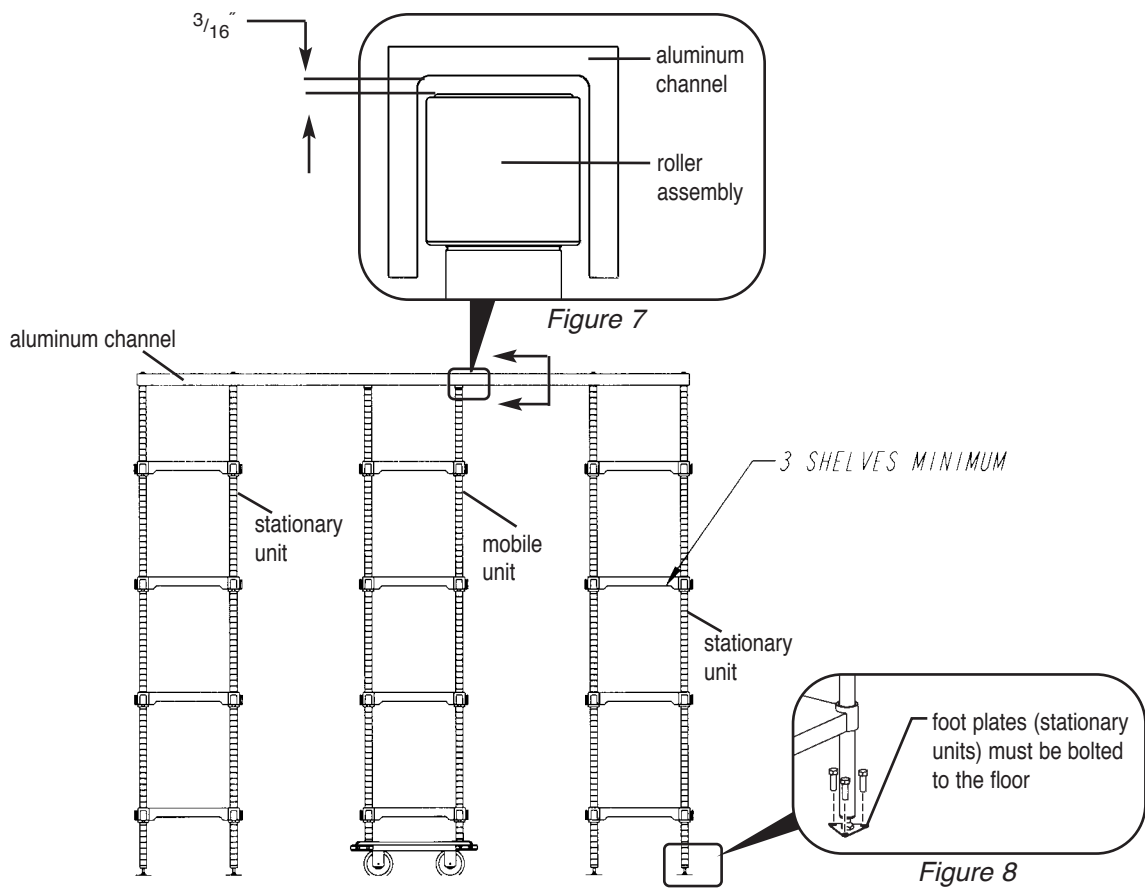

Figure 6

(continued on back page)



Join stationary units, mobile units, and overhead tracks.

6. Line up stationary units and mobile units so posts are in alignment. Stationary end units should tilt outward to give the aluminum channel a positive bow. Adjust stationary units to achieve the tilt.
7. Mount the aluminum channels to the top of the stationary end units. Posts on mobile units must fit inside of channel and move freely. There should be a 3/16" gap between the top of the roller assembly and the bottom of the channel (see Figure 7). Note: Vertical roller should spin freely.
8. Shim aluminum channels if necessary with washers (washers not included). **Bolt the stationary units to the floor** (see Figure 8). This must be done to achieve a positive bow. (Hardware not included to mount to the floor.)
9. Clean the inside of the aluminum track prior to operation.

Notes:

- A maximum of three mobile units and 36" aisle space is allowed before a mid stationary unit is needed.
- Stationary units **MUST BE BOLTED TO THE FLOOR** to prevent movement (see Figure 8).
- Floor must be flat, level and smooth.
- Bearings will not require lubrication.
- Master Trak® units must be mounted a minimum of 6" from walls or other obstructions that would hinder operation of mobile units (see Figure 9). Walls must be plumb and straight to prevent contact with mobile units.

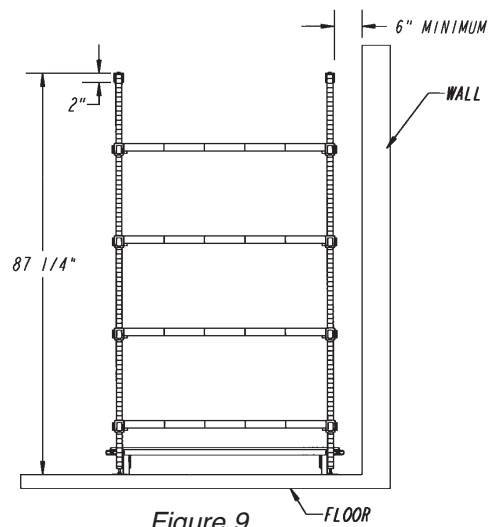

(End)