

# Keyboard Drawer for Tables

## ASSEMBLY INSTRUCTIONS

### CAUTION

INSPECT CONTENTS IMMEDIATELY AND FILE CLAIM WITH DELIVERING CARRIER FOR ANY DAMAGE. **SAVE YOUR BOX AND ALL PACKING MATERIALS.** YOU ARE RESPONSIBLE FOR DAMAGE TO YOUR UNIT IF RETURNED IMPROPERLY PACKED.

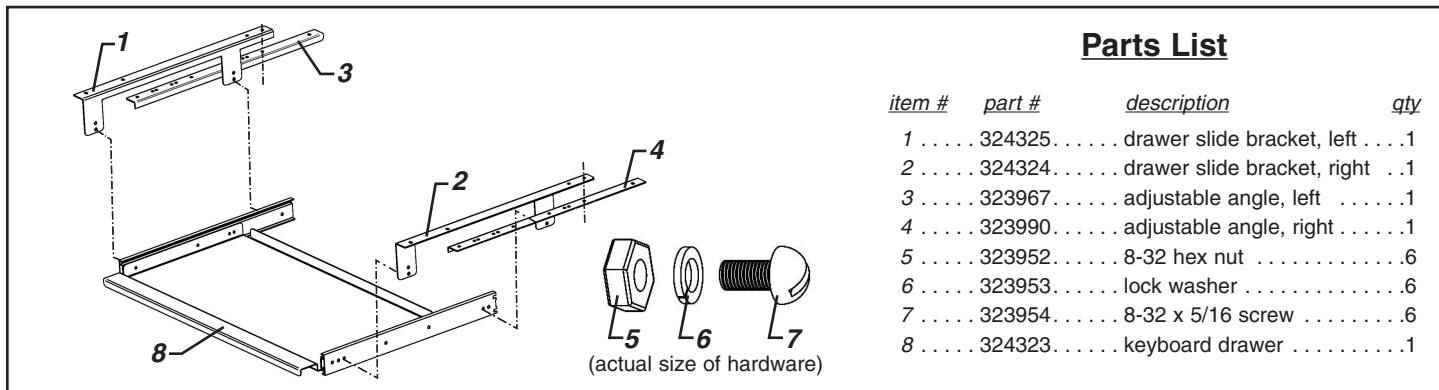

### Parts List

item #	part #	description	qty
1	324325	drawer slide bracket, left	1
2	324324	drawer slide bracket, right	1
3	323967	adjustable angle, left	1
4	323990	adjustable angle, right	1
5	323952	8-32 hex nut	6
6	323953	lock washer	6
7	323954	8-32 x 5/16 screw	6
8	324323	keyboard drawer	1

### Before assembly...

- Gather adjustable angles and drawer slide brackets, separating left set from right set.
- Tools required: flat-head screwdriver; pliers; 3/8" wrench or adjustable wrench.

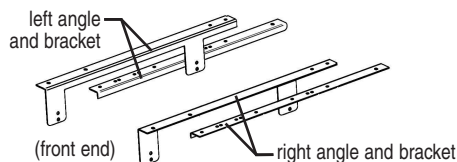

### Step 1 - Determine which holes in angles and in brackets will be used for mounting to table.

- Position left adjustable angle and left drawer slide bracket so that the edges with notches are aligned (see figure 1).
- Find the notch that aligns the front-and-rear screw holes for table attachment (see figure 2). Note which notch will be used.

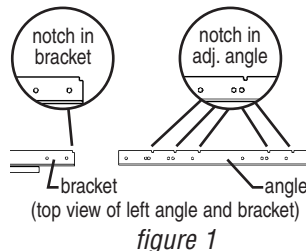

### Step 2 - Attach angles to brackets.

- Attach adjustable angle to bracket (see figure 2) with screw provided.
- Be sure the adjustable angle notch you are using is still aligned with the drawer slide bracket notch.

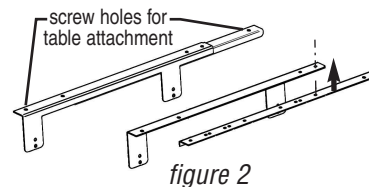

Repeat Steps 1 and 2 to remaining set of angles and brackets.

### Step 3 - Mount angle/bracket assemblies to table.

Screw assembly to your table (see note at bottom of page). Be sure to attach left assembly to the left side and right assembly to the right side.

### Step 4 - Attach drawer to angle/bracket assemblies.

Attach drawer to angle/bracket assemblies via one of the holes in each drawer slide (see figure 3).

Height is adjustable, depending on which hole in each angle/bracket assembly is used.

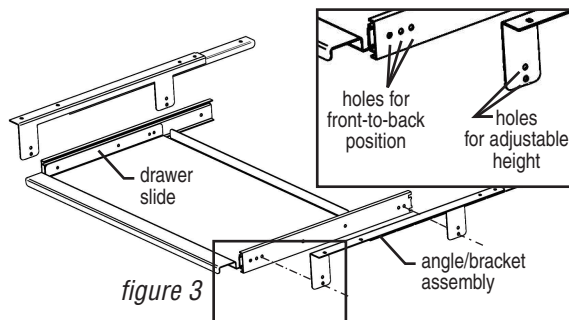

Note: Eagle worktables with channel frame come with screws (located in predrilled holes in channels) for use in mounting drawers. Otherwise, mounting hardware sold separately.

EG9840 Revised 01/11



• 100 Industrial Boulevard, Clayton, Delaware 19938-8903 U.S.A. • www.eaglegrp.com  
 • Phone: 302/653-3000 • (Foodservice) 800/441-8440 • (MHC/Retail) 800/637-5100  
 • Fax: 302/653-2065