



Profit from the Eagle Advantage®

Specification Sheet

Short Form Specifications

18 gauge 300 series stainless work surface welded and finished on all four corners. Legs and H-frame constructed of 16 gauge 300 series 1"-diameter stainless steel tubing. Optional undershelf of 18 gauge 300 series stainless steel. 4" x 1" resilient swivel stem casters. 34" overall height.



instrument table with undershelf

Options / Accessories

- Additional undershelves

EAGLE GROUP

100 Industrial Boulevard, Clayton, DE 19938-8903 USA

Phone: 302-653-3000 • Fax: 302-653-2065

www.eaglegrp.com

Foodservice Division: Phone 800-441-8440

MHC/Retail Display Divisions: Phone 800-637-5100

For custom configuration or fabrication needs, contact our SpecFAB® Division.

Phone: 302-653-3000 • Fax: 302-653-2065 • e-mail: quotes@eaglegrp.com

Item No.: _____
Project No.: _____
S.I.S. No.: _____

Instrument Tables

MODELS:

- | | |
|----------------------------------|----------------------------------|
| <input type="checkbox"/> ITT1620 | <input type="checkbox"/> ITU1620 |
| <input type="checkbox"/> ITT1630 | <input type="checkbox"/> ITU1630 |
| <input type="checkbox"/> ITT1834 | <input type="checkbox"/> ITU1834 |
| <input type="checkbox"/> ITT2036 | <input type="checkbox"/> ITU2036 |
| <input type="checkbox"/> ITT2048 | <input type="checkbox"/> ITU2048 |
| <input type="checkbox"/> ITT2436 | <input type="checkbox"/> ITU2436 |
| <input type="checkbox"/> ITT2446 | <input type="checkbox"/> ITU2446 |
| <input type="checkbox"/> ITT2458 | <input type="checkbox"/> ITU2458 |

Design and Construction Features

- Instrument tables provide an all-stainless work system for use as back tables in the O.R. suite during surgery, or as mobile work stations for any department.
- Heavy gauge type 304 stainless steel top surface, undershelves, and legs.
- Tabletop edges are safety hemmed.
- Tubular 1" (25mm)-diameter legs are used to house the easy-swivel casters for mobility.
- No bacteria-gathering cracks or crevices.
- Available with or without safety hemmed undershelves.



Item No.: _____
 Project No.: _____
 S.I.S. No.: _____

Instrument Tables

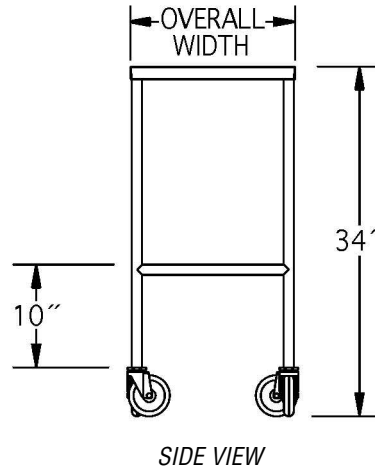
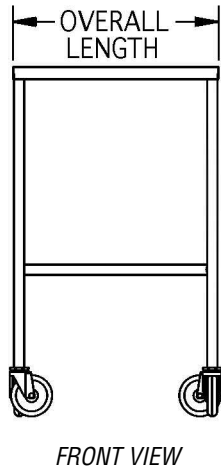
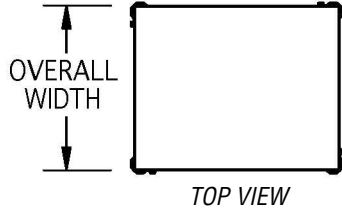

TABLES WITH H-BRACE model #	TABLES WITH UNDERSHELF model #	overall width		overall length		overall height		weight	
		in.	mm	in.	mm	in.	mm	lbs.	kg
ITT1620	ITU1620	16"	406	20"	508	34"	864	25	11.3
ITT1630	ITU1630	16"	406	30"	762	34"	864	30	13.6
ITT1834	ITU1834	18"	457	34"	864	34"	864	33	15.0
ITT2036	ITU2036	20"	508	36"	914	34"	864	36	16.3
ITT2048	ITU2048	20"	508	48"	1219	34"	864	47	21.3
ITT2436	ITU2436	24"	610	36"	914	34"	864	39	17.7
ITT2446	ITU2446	24"	610	46"	1168	34"	864	50	22.7
ITT2458	ITU2458	24"	610	58"	1473	34"	864	59	26.8

EAGLE GROUP
 100 Industrial Boulevard, Clayton, DE 19938-8903 USA
 Phone: 302-653-3000 • Fax: 302-653-2065
 www.eaglegrp.com

Foodservice Division: Phone 800-441-8440
 MHC/Retail Display Divisions: Phone 800-637-5100

Printed in U.S.A.
 ©2016 by Eagle Group
 Rev. 01/16

Spec sheets available for viewing, printing or downloading from our online literature library at www.eaglegrp.com

Although every attempt has been made to ensure the accuracy of the information provided, we cannot be held responsible for typographical or printing errors. Information and specifications are subject to change without notice. Please confirm at time of order.