



Profit from the Eagle Advantage®

Specification Sheet

Short Form Specifications

All stainless steel type 430 enclosed cabinet. Three adjustable shelves on 4" centers, 24"-deep by 36"- or 48"-long. Available with slanted top for laminar flow.



#VSC2436-3 vertical storage cabinet

Options / Accessories

- 5" plate casters w/brake (factory-installed) *
- Additional 36"-long shelves
- Additional 48"-long shelves

* To order casters, add suffix "-CPB5". Example: VSC2436-3-CPB5

EAGLE GROUP

100 Industrial Boulevard, Clayton, DE 19938-8903 USA

Phone: 302-653-3000 • Fax: 302-653-2065

www.eaglegrp.com

Foodservice Division: Phone 800-441-8440

MHC/Retail Display Divisions: Phone 800-637-5100

For custom configuration or fabrication needs, contact our **SpecFAB®** Division.

Phone: 302-653-3000 • Fax: 302-653-3091 • e-mail: specfab@eaglegrp.com

Item No.:	_____
Project No.:	_____
S.I.S. No.:	_____

Vertical Storage Cabinets

MODELS:

- | | | |
|------------------------------------|-------------------------------------|--------------------------------|
| <input type="checkbox"/> VSC2436-3 | <input type="checkbox"/> VSCS2436-3 | <input type="checkbox"/> VSC36 |
| <input type="checkbox"/> VSC2448-3 | <input type="checkbox"/> VSCS2448-3 | <input type="checkbox"/> VSC48 |
| <input type="checkbox"/> VSC2436-4 | <input type="checkbox"/> VSCS2436-4 | |
| <input type="checkbox"/> VSC2448-4 | <input type="checkbox"/> VSCS2448-4 | |

Design and Construction Features

- Features 18 gauge type 430 stainless steel cabinet body.
- Shelves adjustable on 4" (102mm) vertical centers.
- Double-pan 20 gauge stainless steel hinged doors.
- Transverse rod handles featuring keyed locks.
- All units are 24" (610mm) front-to-back.
- Available in 36" and 48" (914 and 1219mm) lengths.
- Available with flat top or slanted top.
- Custom sizes available.

Certifications / Approvals



Item No.:	_____
Project No.:	_____
S.I.S. No.:	_____

Vertical Storage Cabinets

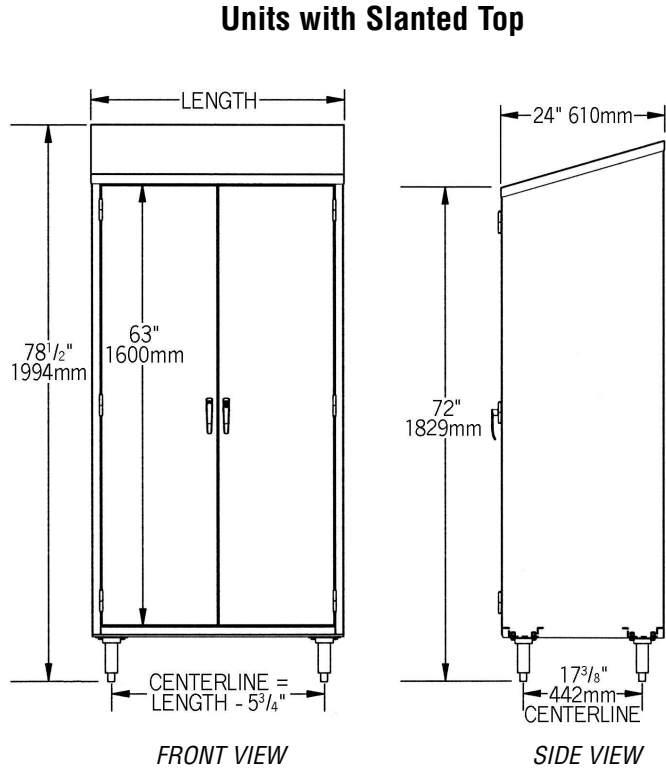
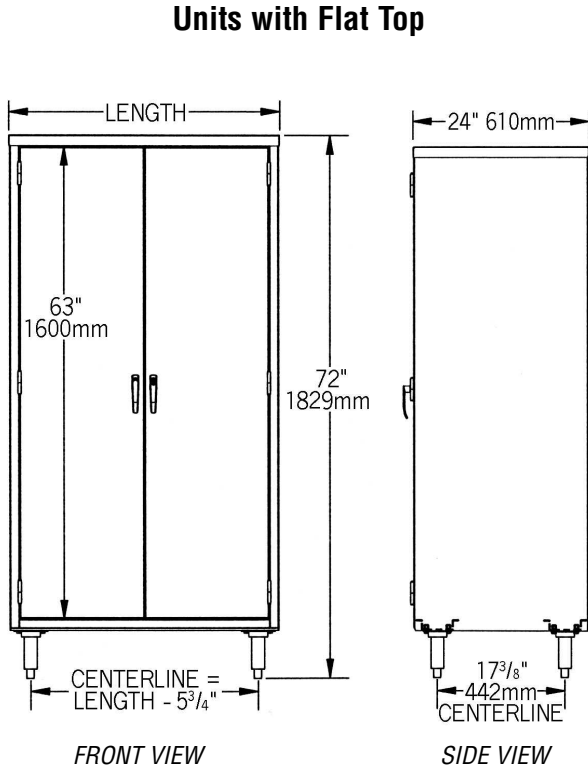

Units with Flat Top				Units with Slanted Top									
Units with 3 Shelves		Units with 4 Shelves		Units with 3 Shelves		Units with 4 Shelves		wt. capacity					
model #	weight	model #	weight	model #	weight	model #	weight	width	length	per shelf			
lbs.	kg	lbs.	kg	lbs.	kg	lbs.	kg	in.	mm	in.	mm	lbs.	kg
VSC2436-3	413 187.3	VSC2436-4	416 188.7	VSCS2436-3	416 188.7	VSCS2436-4	419 190.1	24"	610	36"	914	150	68.0
VSC2448-3	485 220.0	VSC2448-4	490 222.3	VSCS2448-3	488 221.4	VSCS2448-4	495 224.5	24"	610	48"	1219	200	90.7

Optional Additional Shelves

model #	description	weight	
		lbs.	kg
VSC36	fits 36" (914mm) long cabinets	25	11.3
VSC48	fits 48" (1219mm) long cabinets	30	13.6

EAGLE GROUP
100 Industrial Boulevard, Clayton, DE 19938-8903 USA
Phone: 302-653-3000 • Fax: 302-653-2065
www.eaglegrp.com

Foodservice Division: Phone 800-441-8440
MHC/Retail Display Divisions: Phone 800-637-5100

Printed in U.S.A.
©2011 by Eagle Group
Rev. 09/11

Spec sheets available for viewing, printing or downloading from our online literature library at www.eaglegrp.com

Although every attempt has been made to ensure the accuracy of the information provided, we cannot be held responsible for typographical or printing errors. Information and specifications are subject to change without notice. Please confirm at time of order.