

# Cleanroom Tables

## ASSEMBLY INSTRUCTIONS

### CAUTION

INSPECT CONTENTS IMMEDIATELY AND FILE CLAIM WITH DELIVERING CARRIER FOR ANY DAMAGE.

**SAVE YOUR BOX AND ALL PACKING MATERIALS.**

YOU ARE RESPONSIBLE FOR DAMAGE TO YOUR UNIT IF RETURNED IMPROPERLY PACKED.

Please note: Assembly shown for unit with H-frame.

#### Step 1 - Assemble tubular frame.

- Attach knockdown tube to front-to-back crossbracings.
- Tighten bolt at each end.

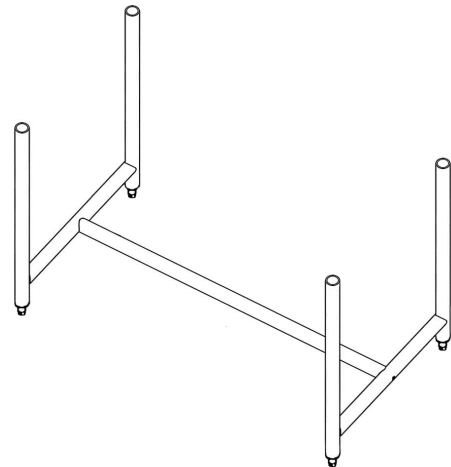
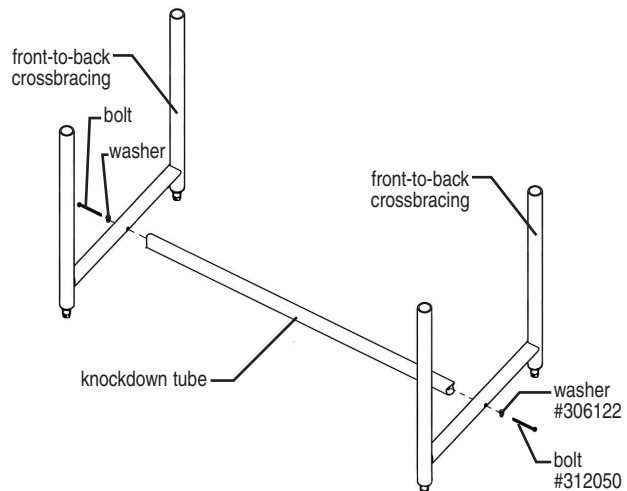

Frame fully assembled.

#### Step 2 - Attach tabletop.

- Turn tabletop upside-down (take care not to scratch the finish).
- Turn tubular frame upside-down and insert top of each leg into each tabletop gusset.
- At each gusset, tighten set screw.

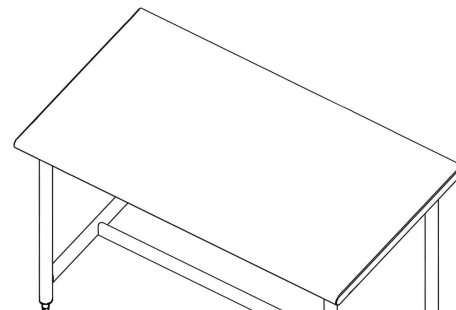
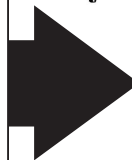
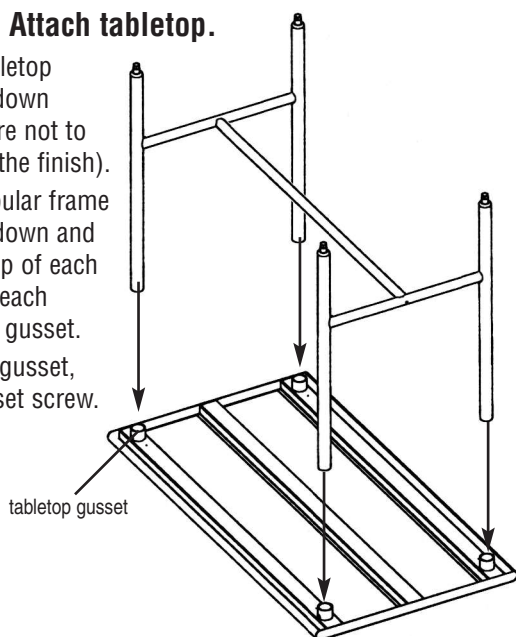

Assembly is complete.

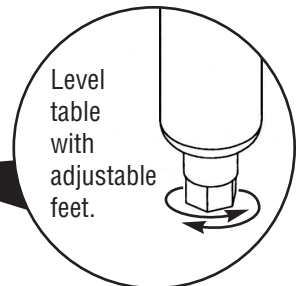

**(End)**

EG9895 Revised 10/14