

Garment Racks

ASSEMBLY INSTRUCTIONS

CAUTION

INSPECT CONTENTS IMMEDIATELY AND FILE CLAIM WITH DELIVERING CARRIER FOR ANY DAMAGE. **SAVE YOUR BOX AND ALL PACKING MATERIALS.** YOU ARE RESPONSIBLE FOR DAMAGE TO YOUR UNIT IF RETURNED IMPROPERLY PACKED.

Parts List

#	qty	description
	2	wire shelf ("GR" and "UR" models) or
#1	2	wire shelf ("GRS" and "URS" models)
	1	solid shelf
#2	4	post
#3	8	pair of split sleeves
#4	1	hanger tube
#5	2	wire hanger frame
#6	4	washer for hanger tube
#7	2	bolt for hanger tube

Note: "UR" and URS" units come with four (4) casters.

(actual size of hardware)

If you have a mobile unit, attach casters to posts now.

Insert caster into bottom of each post and drive in, using a mallet or hammer (see below).

Afterwards, go to **Step 1**

Step 1

Snap the plastic split sleeves onto each post at the desired location of the bottom wire shelf.

Note: The wider part of the split sleeve is the bottom.

Step 2

Lower the bottom wire shelf onto split sleeves.

If you have a "GRS" or "URS" model, repeat **Steps 1 & 2** to install solid shelf at 8" minimum above bottom wire shelf.

(continued on back page)

Garment Racks

ASSEMBLY INSTRUCTIONS

Step 3

Snap the plastic split sleeves onto each post at the desired location of the top wire shelf (typically the topmost groove in each post).

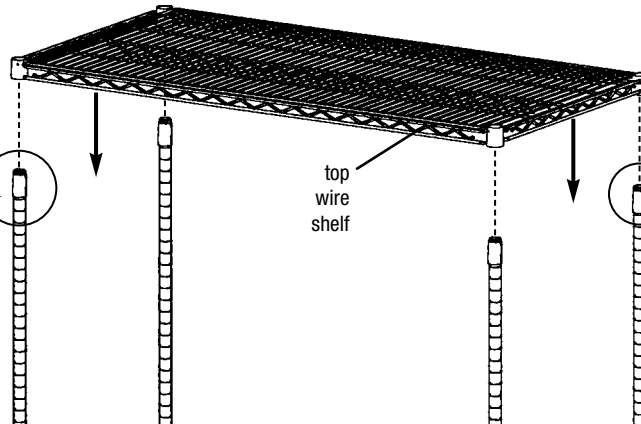
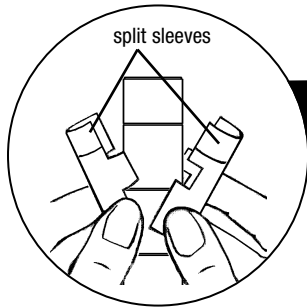

Step 4

Lower the top wire shelf onto split sleeves.

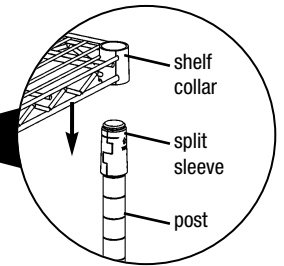

Step 5

Assemble hanger bar.

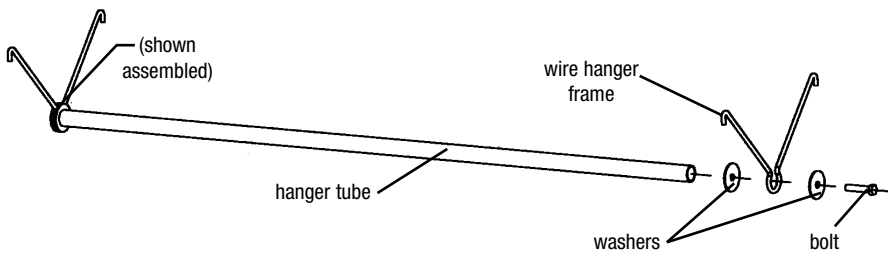

Step 6

Attach hanger bar assembly to underside of top wire shelf.

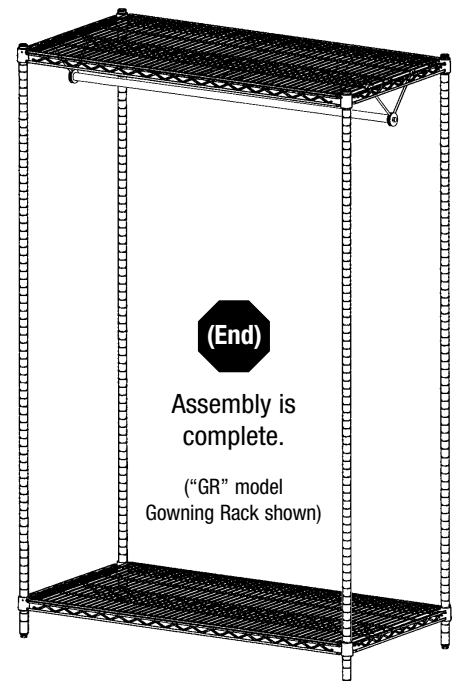
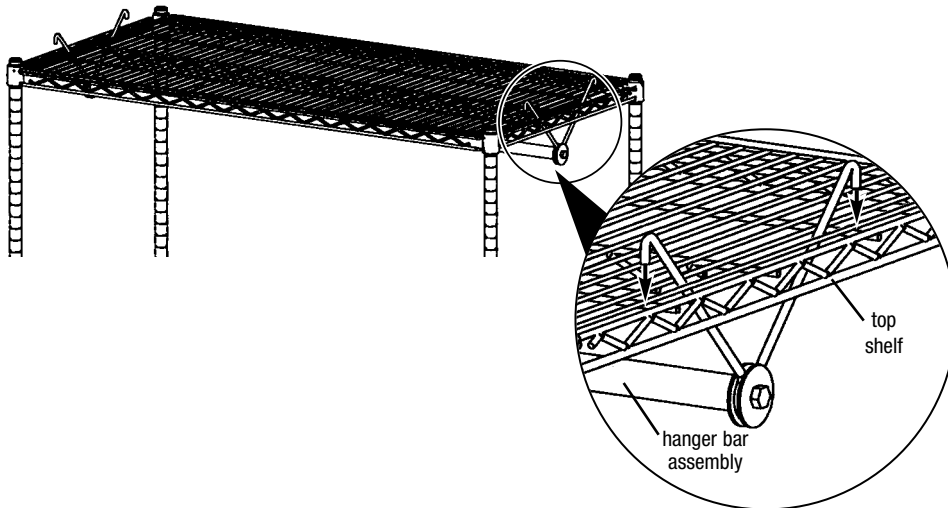

(End)

Assembly is complete.

("GR" model Gowning Rack shown)