

Wire Gowning Bench

ASSEMBLY INSTRUCTIONS

CAUTION

INSPECT CONTENTS IMMEDIATELY AND FILE CLAIM WITH DELIVERING CARRIER FOR ANY DAMAGE. **SAVE YOUR BOX AND ALL PACKING MATERIALS.** YOU ARE RESPONSIBLE FOR DAMAGE TO YOUR UNIT IF RETURNED IMPROPERLY PACKED.

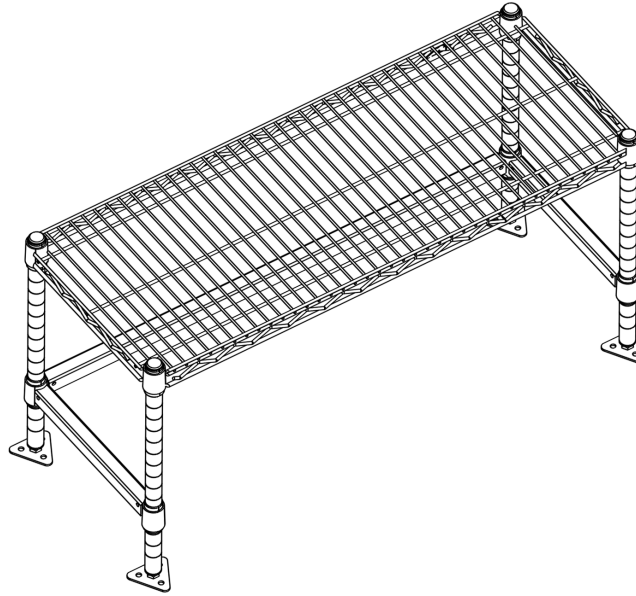

Thank you for your purchase. Before assembly, read this instruction sheet carefully. After reading, be sure to store this instruction in a safe place, should it be needed for future reference.

Parts List

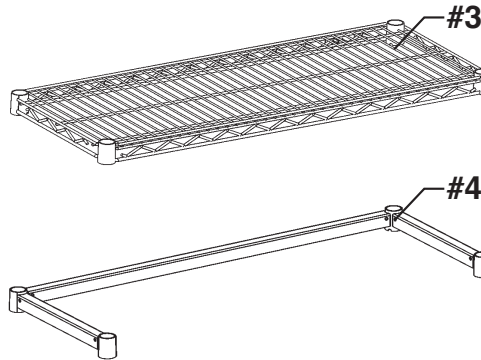
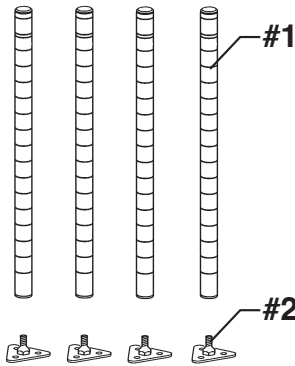

#	qty	description
#1	4	post
#2	4	footplate
#3	1	seat
#4	1	3-sided channel frame
#5	8	pair of split sleeves

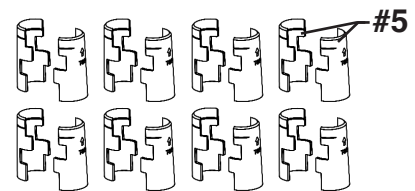

(continued on next page)

Wire Gowning Bench

ASSEMBLY INSTRUCTIONS

Step 1

Attach footplates to bottom of posts.

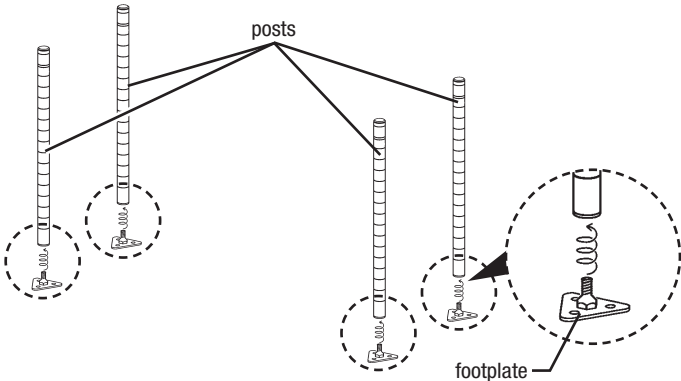

Step 2

Attach split sleeves (for 3-sided channel frame) to posts.
Note: Wider part of the taper goes toward the bottom.

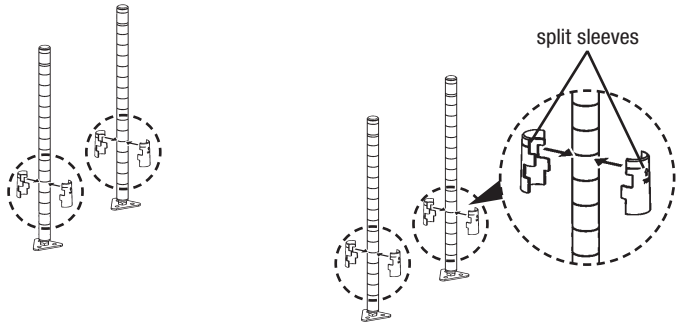

Step 3

Slide 3-sided channel frame down posts and onto split sleeves.

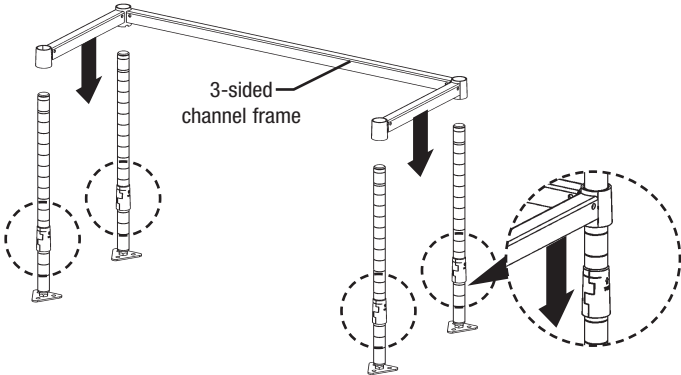

Step 4

Attach split sleeves (for seat) to top groove in posts.

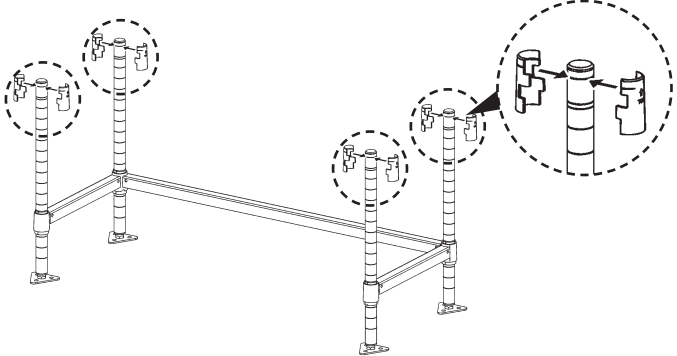

Step 5

Affix seat onto split sleeves.

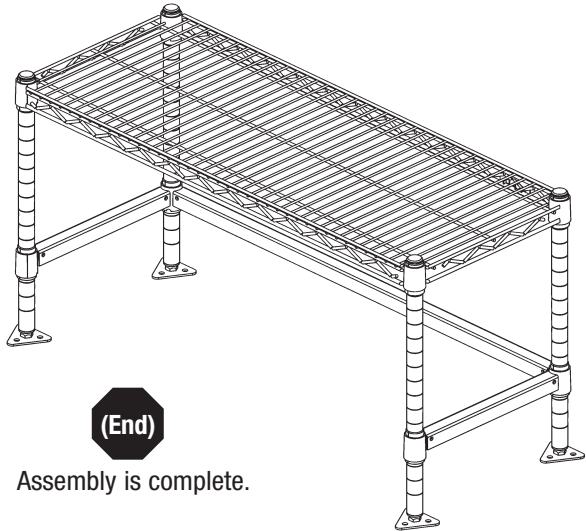
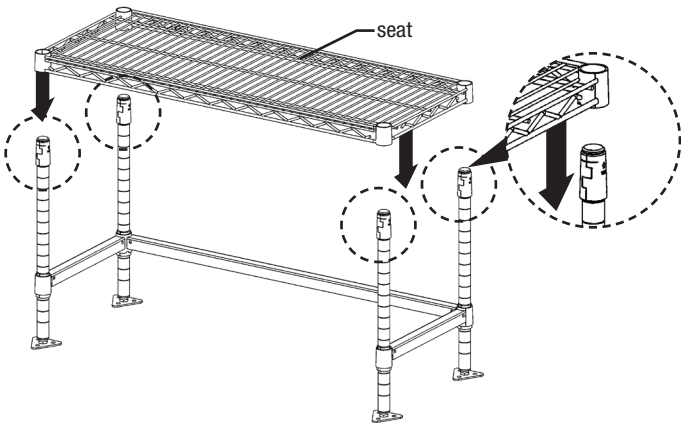

(End)

Assembly is complete.