

Hanger Bar Kits

ASSEMBLY INSTRUCTIONS

CAUTION

INSPECT CONTENTS IMMEDIATELY AND FILE CLAIM WITH DELIVERING CARRIER FOR ANY DAMAGE. **SAVE YOUR BOX AND ALL PACKING MATERIALS.** YOU ARE RESPONSIBLE FOR DAMAGE TO YOUR UNIT IF RETURNED IMPROPERLY PACKED.

Thank you for your purchase. Before assembly, read this instruction sheet carefully. After reading, be sure to store this instruction in a safe place, should it be needed for future reference.

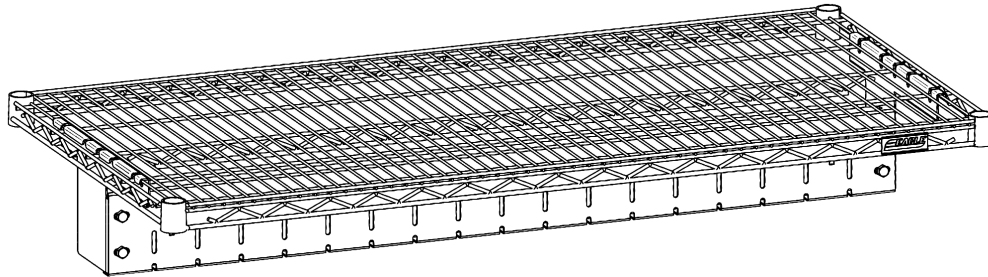

(shown attached to wire shelf)

Parts List

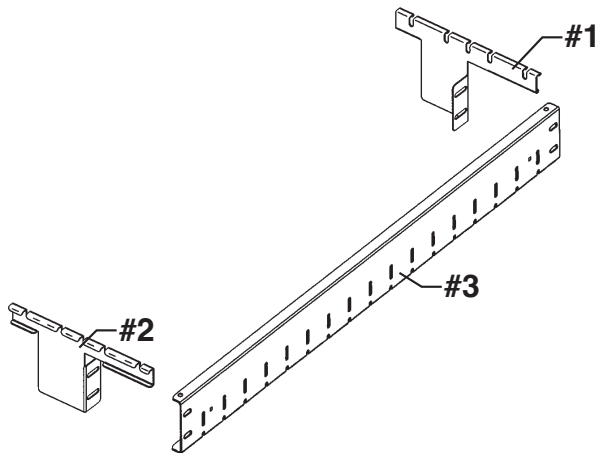

#	qty	part #	description
#1	1	*	right hanger bar bracket
#2	1	*	left hanger bar bracket
#3	1	*	hanger bar
#4	4	306138	3/8"-16 x 3/4" bolt
#5	4	312049	3/8" hex nut

* Size and/or finish determines part number.

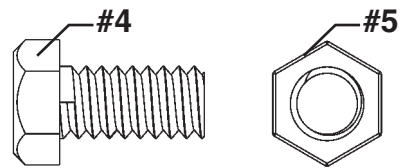

(actual size of hardware)

Please note:

These instructions show how to fit a Hanger Bar Kit onto the wire shelf of a wall-mounted or freestanding shelf unit. Referring to instructions that came with shelf unit, assemble the shelf unit before installing Hanger Bar Kit.

(continued on next page)

EG10117 Revised 02/24

Hanger Bar Kits

ASSEMBLY INSTRUCTIONS

Step 1

- Position left and right hanger bar brackets so that the front flange of each bracket faces inward.
- From underside of wire shelf, hook each hanger bar bracket onto the front-to-back truss that is 2nd from each end of wire shelf, as shown.

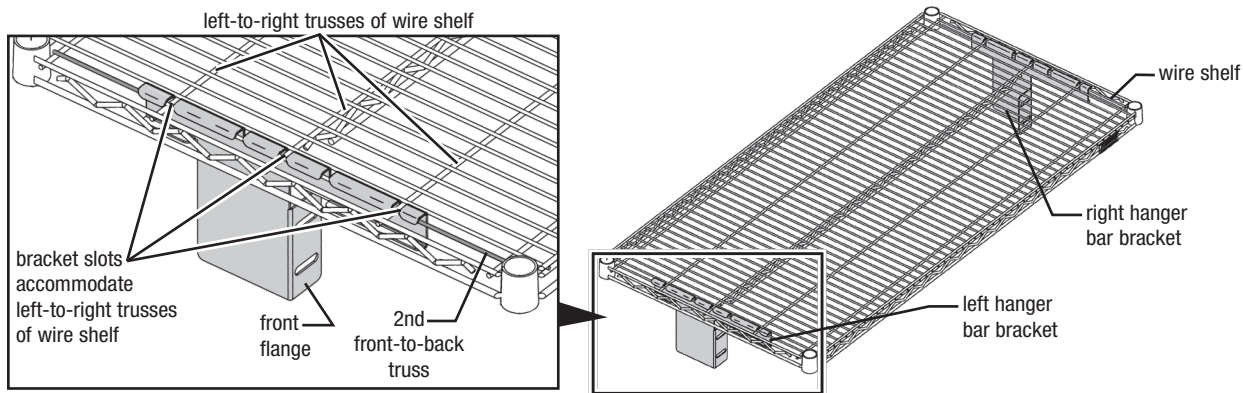

Step 2

Using hardware provided, attach hanger bar to left and right hanger bar brackets, as shown.

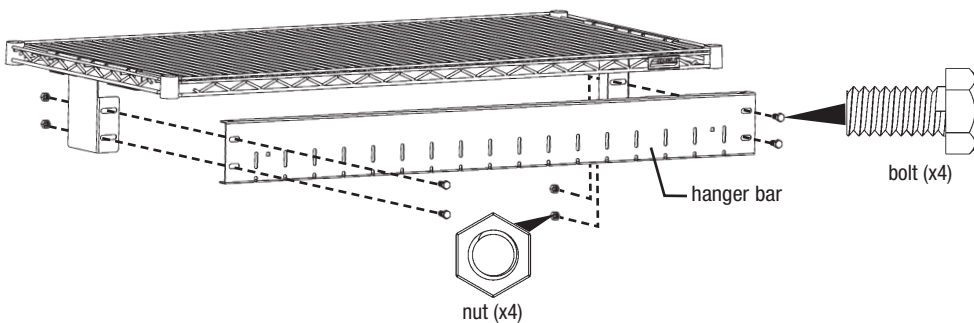

(End)

Assembly is complete.



WARNING – IMPORTANT NOTES



- Heavier objects should be stored at lower levels.
- Always be sure shelves are properly leveled.
- Do not step, stand, climb, or hang on shelving.
- Do not drop heavy objects onto shelves.
- Never overload shelving.

Failure to follow these guidelines can result in property damage or personal injury.



- 100 Industrial Boulevard, Clayton, Delaware 19938-8903 U.S.A.
- Phone: 302/653-3000 • 800/441-8440 • Fax: 302/653-2065
- www.eaglegrp.com • www.eaglehmc.com