



Profit from the Eagle Advantage®

Specification Sheet

Short Form Specifications

Eagle Mobile Partitions can be used to divide spaces, route traffic flow, and provide flexible full height shield options that may be reconfigured and moved as room layouts and conditions change. Available with full screen, full screen with 2" access hole (for temperature taking) 60" above floor level, and half screen.



with access hole



with half screen

Item No.:	_____
Project No.:	_____
S.I.S. No.:	_____

Mobile Partitions

MODELS:

- BGMP-3072
- BGMP-3072-TT
- BGMP-3072-TH

Design and Construction Features

- 7/32"-thick durable plexiglass.
- 1" stainless steel tubing frame.
- 1-1/2" stainless tubing base.
- 2" twin wheel casters.
- Nestable for storage.

Options / Accessories

- Upgrade to polycarbonate
- Company logo added
- Custom edge banding
- Custom configurations

EAGLE GROUP

100 Industrial Boulevard
Clayton, DE 19938-8903 USA

Phone: 302-653-3000 • 800-441-8440

Fax: 302-653-2065

www.eaglegrp.com • www.eaglemhc.com

For custom configuration or fabrication needs, contact our **SpecFAB®** Division.

Phone: 302-653-3000 • Fax: 302-653-2065 • e-mail: quotes@eaglegrp.com

Certifications / Approvals



SEFA 8 Metal Casework

EG06.08 Rev. 11/20

Spec sheets available for viewing, printing or downloading from our online literature library at www.eaglegrp.com

Eagle Foodservice Equipment, Eagle MHC, and SpecFAB® are divisions of Eagle Group. ©2020 by the Eagle Group



Item No.: _____
 Project No.: _____
 S.I.S. No.: _____

Mobile Partitions

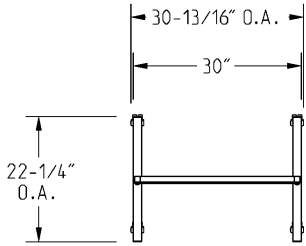

TOP VIEW OF ALL UNITS

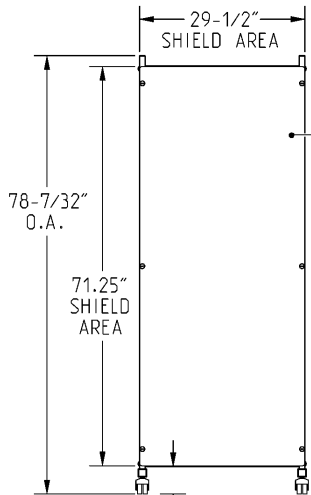

FRONT VIEW OF #BGMP-3072

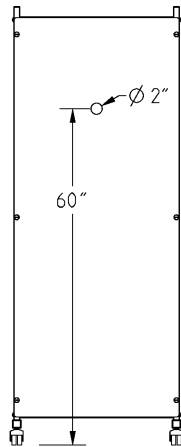

FRONT VIEW OF #BGMP-3072-TT

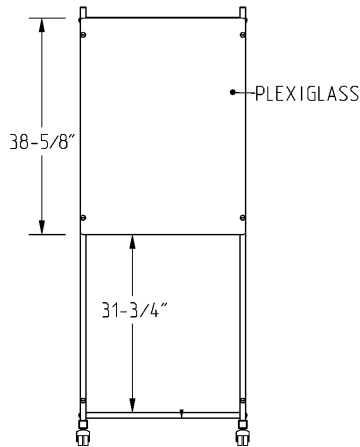

FRONT VIEW OF #BGMP-3072-TH

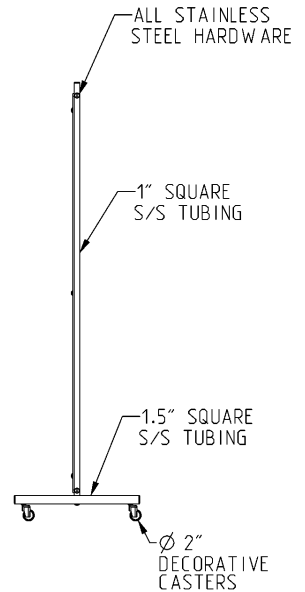

SIDE VIEW OF ALL UNITS

description	height		width		model #
	in	mm	in	mm	
full screen, solid	72"	1829	30"	762	BGMP-3072
full screen, 2"-dia. access hole	72"	1829	30"	762	BGMP-3072-TT
half screen	72"	1829	30"	762	BGMP-3072-TH

EAGLE GROUP
 100 Industrial Boulevard, Clayton, DE 19938-8903 USA
 Phone: 302-653-3000 or 800-441-8440 • Fax: 302-653-2065
 www.eaglegrp.com • www.eaglehmc.com

Printed in U.S.A.
 ©2020 by Eagle Group
 Rev. 11/20

Spec sheets available for viewing, printing or downloading from our online literature library at www.eaglegrp.com

Although every attempt has been made to ensure the accuracy of the information provided, we cannot be held responsible for typographical or printing errors. Information and specifications are subject to change without notice. Please confirm at time of order.