



Profit from the Eagle Advantage®

# Specification Sheet

## Short Form Specifications

Eagle Wall Mounted Multi-Station Hand Sink with Electronic-Eye Faucet, model \_\_\_\_\_. Heavy duty 14 gauge stainless steel construction. 9½" high backsplash with 2" return. 1½"-diameter 16 gauge stainless steel tubular supports and gussets. Offered in lengths ranging from 48" to 96". Electronic-eye faucets with 120-volt AC adapter and backsplash-mounted gooseneck spouts.



#HSA-WM-48-FE

Item No.:	_____
Project No.:	_____
S.I.S. No.:	_____

## Electronic-Eye Wall Mounted Multi-Station Hand Sinks—AC Power

### MODELS:

- HSA-WM-48-FE
- HSA-WM-60-FE
- HSA-WM-72-FE
- HSA-WM-96-FE

### Design and Construction Features

- Single full-length bowl with basket drain(s) and rolled edge.
- 14 gauge type 304 stainless steel construction.
- Wall-mounted tubular supports consists of 16 gauge 1½" (41mm)-diameter tubing.
- Stainless steel basket drain assembly (two on #HSA-WM-96-FE).
- 9½" backsplash, with single faucet holes.
- Supplied with backsplash to wall mount "Z" brackets.
- 21½" overall front-to-back.
- Lengths available range from 48" to 96" (1219 to 2438mm).
- Electronic-eye faucets with gooseneck spout.

### Options / Accessories

- Battery-Operated Faucets\*
- Lever Handle Drains
- Twist Handle Drains

\* To order battery-powered electronic eye faucet in place of 120V version, add suffix -B to the end of the model number. Example: HSA-WM-48-FE-B

### EAGLE GROUP

100 Industrial Boulevard  
Clayton, DE 19938-8903 USA

Phone: 302-653-3000 • 800-441-8440

Fax: 302-653-2065

www.eaglegrp.com • www.eaglemh.com

For custom configuration or fabrication needs, contact our SpecFAB® Division.

Phone: 302-653-3000 • Fax: 302-653-2065 • e-mail: quotes@eaglegrp.com

EG05.20C Rev. 02/22

Spec sheets available for viewing, printing or downloading from our online literature library at [www.eaglegrp.com](http://www.eaglegrp.com)

Eagle Foodservice Equipment, Eagle MHC, and SpecFAB® are divisions of Eagle Group. ©2022 by the Eagle Group

Item No.: \_\_\_\_\_  
Project No.: \_\_\_\_\_  
S.I.S. No.: \_\_\_\_\_

## Electronic-Eye Wall Mounted Multi-Station Hand Sinks

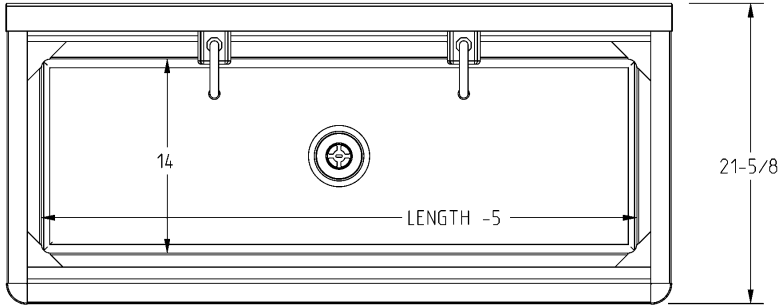

TOP VIEW

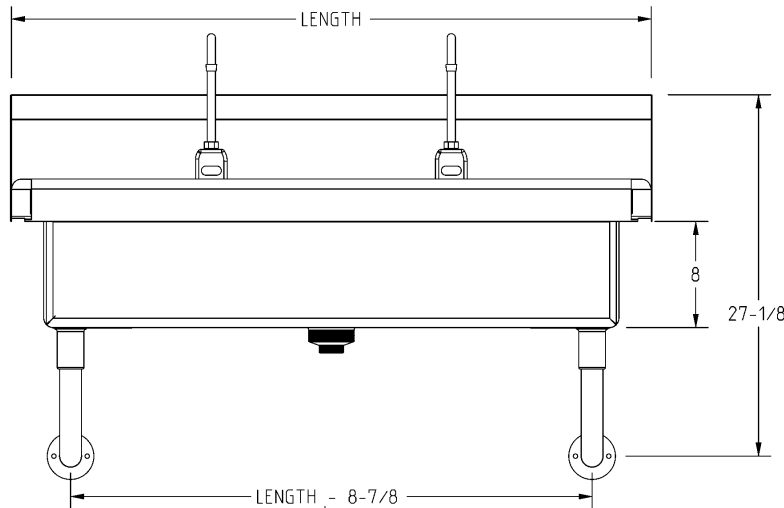

FRONT VIEW

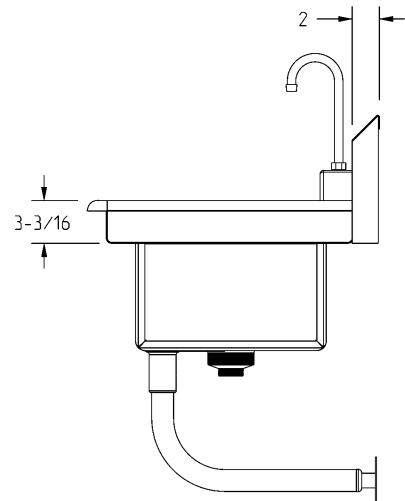

SIDE VIEW

overall width x length x height in. mm		bowl width x length x depth in. mm		# of faucets included	weight lbs. kg		model #
21 $\frac{1}{2}$ " x 48" x 27 $\frac{1}{8}$ "	549 x 1219 x 689	14" x 43" x 8"	356 x 1092 x 203	2	74	33.6	<b>HSA-WM-48-FE</b>
21 $\frac{1}{2}$ " x 60" x 27 $\frac{1}{8}$ "	549 x 1524 x 689	14" x 55" x 8"	356 x 1397 x 203	2	85	38.6	<b>HSA-WM-60-FE</b>
21 $\frac{1}{2}$ " x 72" x 27 $\frac{1}{8}$ "	549 x 1829 x 689	14" x 67" x 8"	356 x 1702 x 203	3	100	45.4	<b>HSA-WM-72-FE</b>
21 $\frac{1}{2}$ " x 96" x 27 $\frac{1}{8}$ "	549 x 2438 x 689	14" x 91" x 8"	356 x 2311 x 203	4	128	58.1	<b>HSA-WM-96-FE*</b>

\* Model #HSA-WM-96-FE features three tubular supports and two drains.

**EAGLE GROUP**  
100 Industrial Boulevard, Clayton, DE 19938-8903 USA  
Phone: 302-653-3000 or 800-441-8440 • Fax: 302-653-2065  
www.eaglegrp.com • www.eaglehmc.com

Printed in U.S.A.  
©2022 by Eagle Group  
Rev. 02/22

Spec sheets available for viewing, printing or downloading from our online literature library at [www.eaglegrp.com](http://www.eaglegrp.com)

Although every attempt has been made to ensure the accuracy of the information provided, we cannot be held responsible for typographical or printing errors. Information and specifications are subject to change without notice. Please confirm at time of order.