



Profit from the Eagle Advantage®

Specification Sheet

Short Form Specifications

Constructed of 300 series stainless steel 17" wide by 24½" long. Overall height to the work surface of 35". Wire ledge on three sides of the work surface. Two pull-out drawers with positive stops, one open shelf, and one pull-out tray. 5"-diameter swivel plate casters—two with brakes.



#CTC1724 clinic treatment cart

Item No.:	_____
Project No.:	_____
S.I.S. No.:	_____

Clinic Treatment Cart

MODELS:

CTC1724

Design and Construction Features

- Well suited for use in any treatment area to hold supplies and instruments.
- Designed with cleanliness in mind—all components have safety edges and are free of bacteria gathering crevices.
- All type 304 stainless steel.
- Flat-top work surface, with wire ledge on three sides.
- Pull-out tray with recessed handle and stop—for increased working surface.
- Open shelf located underneath pull-out tray.
- Two large easy-glide pull-out drawers with heavy-duty pull flange and positive stops.
- Four swivel chrome-plated 5" (127mm) casters—two with brake.
- Side-mounted disposal container.

EAGLE GROUP

100 Industrial Boulevard, Clayton, DE 19938-8903 USA

Phone: 302-653-3000 • Fax: 302-653-2065

www.eaglegrp.com

Foodservice Division: Phone 800-441-8440

MHC/Retail Display Divisions: Phone 800-637-5100

For custom configuration or fabrication needs, contact our SpecFAB® Division.

Phone: 302-653-3000 • Fax: 302-653-3091 • e-mail: specfab@eaglegrp.com

EG05.16 Rev. 02/09

Spec sheets available for viewing, printing or downloading from our online literature library at www.eaglegrp.com

Eagle Foodservice Equipment, Eagle MHC, SpecFAB®, and Retail Display are divisions of Eagle Group. ©2008 by the Eagle Group



Profit from the Eagle Advantage®

Item No.: _____
 Project No.: _____
 S.I.S. No.: _____

Clinic Treatment Cart

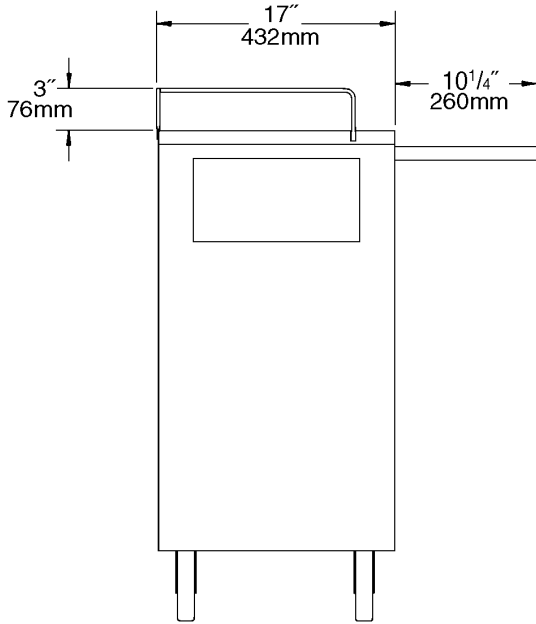

FRONT VIEW

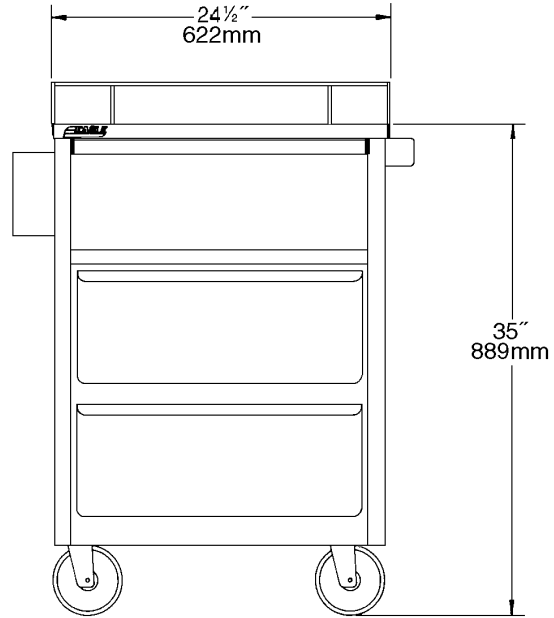

SIDE VIEW

model #	width		length		weight	
	in.	mm	in.	mm	lbs.	kg
CTC1724	17"	432	24 1/2"	622	170	77.1

EAGLE GROUP
 100 Industrial Boulevard, Clayton, DE 19938-8903 USA
 Phone: 302-653-3000 • Fax: 302-653-2065
 www.eaglegrp.com

Foodservice Division: Phone 800-441-8440
 MHC/Retail Display Divisions: Phone 800-637-5100

Printed in U.S.A.
 ©2008 by Eagle Group
 Rev. 02/09

Spec sheets available for viewing, printing or downloading from our online literature library at www.eaglegrp.com

Although every attempt has been made to ensure the accuracy of the information provided, we cannot be held responsible for typographical or printing errors. Information and specifications are subject to change without notice. Please confirm at time of order.