



Profit from the Eagle Advantage®

Specification Sheet

Short Form Specifications

Solid 14 gauge type 304 worksurface with electropolished stainless steel finish. Available with 1½" C-frame or H-frame tubular base, or with undershelf base. Uni-lok® gusset system. Stainless bullet feet adjustable to 1".



table shown with C-frame base

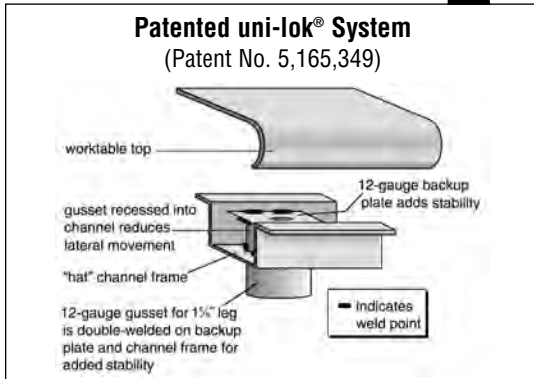

Options / Accessories

- Welded construction C-frame
- Welded construction H-frame

EAGLE GROUP

100 Industrial Boulevard
Clayton, DE 19938-8903 USA

Phone: 302-653-3000 • 800-441-8440

Fax: 302-653-2065

www.eaglegrp.com • www.eaglemhc.com

For custom configuration or fabrication needs, contact our SpecFAB® Division.

Phone: 302-653-3000 • Fax: 302-653-2065 • e-mail: quotes@eaglegrp.com

Item No.: _____
 Project No.: _____
 S.I.S. No.: _____

Cleanroom Tables with Electropolished Solid Tabletop

MODELS:

- | | | |
|-------------------------------------|-------------------------------------|-------------------------------------|
| <input type="checkbox"/> SEP2424T-* | <input type="checkbox"/> SEP2484T-* | <input type="checkbox"/> SEP3084T-* |
| <input type="checkbox"/> SEP2436T-* | <input type="checkbox"/> SEP3036T-* | <input type="checkbox"/> SEP3636T-* |
| <input type="checkbox"/> SEP2448T-* | <input type="checkbox"/> SEP3048T-* | <input type="checkbox"/> SEP3648T-* |
| <input type="checkbox"/> SEP2460T-* | <input type="checkbox"/> SEP3060T-* | <input type="checkbox"/> SEP3660T-* |
| <input type="checkbox"/> SEP2472T-* | <input type="checkbox"/> SEP3072T-* | <input type="checkbox"/> SEP3672T-* |

* See chart on back for complete model numbers.

Design and Construction Features

- Heavy gauge type 304 all stainless steel construction.
- Tops are 14 gauge electropolished stainless steel, reinforced with heavy gauge hat channels. Alcohol-wiped and cleanroom bagged.
- 1½" (38mm)-diameter, rolled down edges at front and rear.
- Ends turned down 90° at 1½" (38mm) providing for flush installations when required.
- Base assembly incorporates the "strength by design" patented uni-lok® (patent #5,165,349) stainless steel gusset system which is welded into hat channel, reducing lateral movement.
- Legs and crossbracing are 16 gauge 1½" (41mm)-diameter, with welded crossbracing front-to-back and choice of center or rear knocked-down crossbracing.
- Undershelves are heavy gauge construction with hat channel reinforcement on tables 84" (2134mm) and longer.
- Tables supplied with 1" (25mm) adjustable stainless steel bullet feet.
- All tables provided with stainless steel assembly hardware and are shipped knock-down.
- 35½" overall height.
- Custom sizes available.



Item No.: _____
 Project No.: _____
 S.I.S. No.: _____

Cleanroom Tables with Electropolished Solid Tabletop

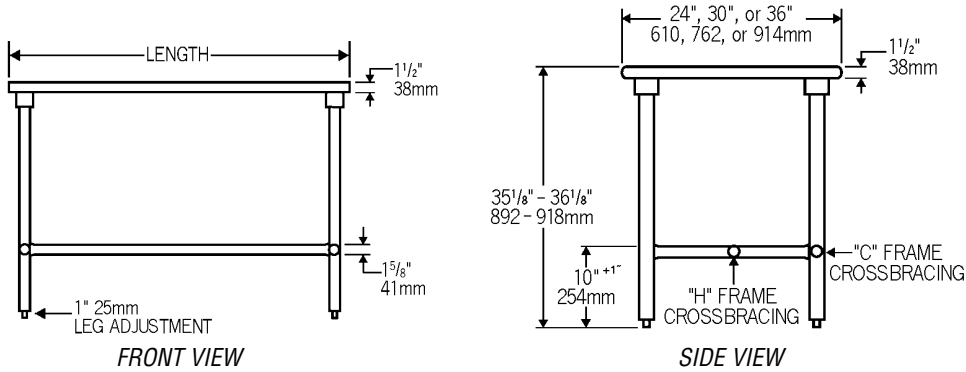

			width		length		weight	
...with C-Frame Base	...with H-Frame Base	...with Undershef Base	in.	mm	in.	mm	lbs.	kg
SEP2424T-C	SEP2424T-H	SEP2424T-US	24"	610	24"	610	40	18.1
SEP2436T-C	SEP2436T-H	SEP2436T-US	24"	610	36"	914	50	22.7
SEP2448T-C	SEP2448T-H	SEP2448T-US	24"	610	48"	1219	60	27.3
SEP2460T-C	SEP2460T-H	SEP2460T-US	24"	610	60"	1524	68	30.9
SEP2472T-C	SEP2472T-H	SEP2472T-US	24"	610	72"	1829	86	39.1
SEP2484T-C	SEP2484T-H	SEP2484T-US	24"	610	84"	2134	90	40.8
SEP3036T-C	SEP3036T-H	SEP3036T-US	30"	762	36"	914	52	23.6
SEP3048T-C	SEP3048T-H	SEP3048T-US	30"	762	48"	1219	65	29.5
SEP3060T-C	SEP3060T-H	SEP3060T-US	30"	762	60"	1524	76	34.5
SEP3072T-C	SEP3072T-H	SEP3072T-US	30"	762	72"	1829	89	40.5
SEP3084T-C	SEP3084T-H	SEP3084T-US	30"	762	84"	2134	101	45.8
SEP3636T-C	SEP3636T-H	SEP3636T-US	36"	914	36"	914	60	27.3
SEP3648T-C	SEP3648T-H	SEP3648T-US	36"	914	48"	1219	73	33.2
SEP3660T-C	SEP3660T-H	SEP3660T-US	36"	914	60"	1524	85	38.6
SEP3672T-C	SEP3672T-H	SEP3672T-US	36"	914	72"	1829	100	45.4

EAGLE GROUP
 100 Industrial Boulevard, Clayton, DE 19938-8903 USA
 Phone: 302-653-3000 or 800-441-8440 • Fax: 302-653-2065
 www.eaglegrp.com • www.eaglemh.com

Printed in U.S.A.
 ©2021 by Eagle Group
 Rev. 05/21

Spec sheets available for viewing, printing or downloading from our online literature library at www.eaglegrp.com

Although every attempt has been made to ensure the accuracy of the information provided, we cannot be held responsible for typographical or printing errors. Information and specifications are subject to change without notice. Please confirm at time of order.