

Item No.: \_\_\_\_\_  
 Project No.: \_\_\_\_\_  
 S.I.S. No.: \_\_\_\_\_

## Specification Sheet

### Short Form Specifications

All stainless steel type 304 enclosed cabinet. 13"- or 16"-deep. Flat top units are 31"-high, sloped top units are 36"-high. Widths range from 18" to 48". Removable back panel. Two adjustable shelves. Doors are inset double-panel construction, mounted with five-knuckle hinges and provided with 4" wire pull handle and roller catch. Designed and tested to the SEFA 8 Metal Casework recommended practices.

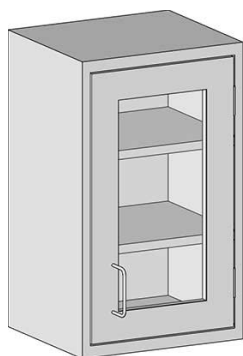

SSC-WCGHR-1324

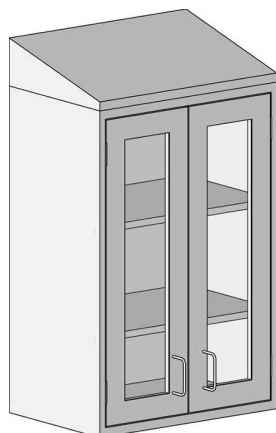

SSC-WCGHST-1630

## Upper Cabinets—Framed Glass Swinging Wall Cases

### MODELS:

- |   |   |
|---|---|
| <input type="checkbox"/> SSC-WCGHL-1318 | <input type="checkbox"/> SSC-WCGHLST-1318 |
| <input type="checkbox"/> SSC-WCGHR-1318 | <input type="checkbox"/> SSC-WCGHRST-1318 |
| <input type="checkbox"/> SSC-WCGHL-1324 | <input type="checkbox"/> SSC-WCGHLST-1324 |
| <input type="checkbox"/> SSC-WCGHR-1324 | <input type="checkbox"/> SSC-WCGHRST-1324 |
| <input type="checkbox"/> SSC-WCGH-1330  | <input type="checkbox"/> SSC-WCGHST-1330  |
| <input type="checkbox"/> SSC-WCGH-1336  | <input type="checkbox"/> SSC-WCGHST-1336  |
| <input type="checkbox"/> SSC-WCGH-1348  | <input type="checkbox"/> SSC-WCGHST-1348  |
| <input type="checkbox"/> SSC-WCGHL-1618 | <input type="checkbox"/> SSC-WCGHLST-1618 |
| <input type="checkbox"/> SSC-WCGHR-1618 | <input type="checkbox"/> SSC-WCGHRST-1618 |
| <input type="checkbox"/> SSC-WCGHL-1624 | <input type="checkbox"/> SSC-WCGHLST-1624 |
| <input type="checkbox"/> SSC-WCGHR-1624 | <input type="checkbox"/> SSC-WCGHRST-1624 |
| <input type="checkbox"/> SSC-WCGH-1630  | <input type="checkbox"/> SSC-WCGHST-1630  |
| <input type="checkbox"/> SSC-WCGH-1636  | <input type="checkbox"/> SSC-WCGHST-1636  |
| <input type="checkbox"/> SSC-WCGH-1648  | <input type="checkbox"/> SSC-WCGHST-1648  |

### Design and Construction Features

- Type 304 stainless steel construction.
- Two intermediate shelves, adjustable on 1½" (38mm) increments.
- Available with 13" or 16" (330 or 406mm) depth.
- Widths range from 18" to 48" (457 to 1219mm).
- Offered with single left- or right-swing door, or with double doors.
- Doors are double-panel inset construction with five-knuckle hinges, 4" wire pull, and roller catch.
- ¼" (6mm)-thick tempered glass panels.
- Units with flat top are 31" (889mm) high.
- Units with sloped top are 36" (914mm) high.

### Options / Accessories

- Door locks
- Additional shelves
- Custom door pulls
- Custom sizes

### Certifications / Approvals



SEFA 8 Metal Casework

### EAGLE GROUP

100 Industrial Boulevard  
 Clayton, DE 19938-8903 USA

Phone: 302-653-3000 • 800-441-8440

Fax: 302-653-2065

www.eaglegrp.com • www.eaglemh.com

For custom configuration or fabrication needs, contact our SpecFAB® Division.

Phone: 302-653-3000 • Fax: 302-653-2065 • e-mail: quotes@eaglegrp.com

EG03.32 Rev. 11/21

Spec sheets available for viewing, printing or downloading from our online literature library at [www.eaglegrp.com](http://www.eaglegrp.com)

Item No.: \_\_\_\_\_  
 Project No.: \_\_\_\_\_  
 S.I.S. No.: \_\_\_\_\_

## Upper Cabinets—Framed Glass Swinging Wall Cases

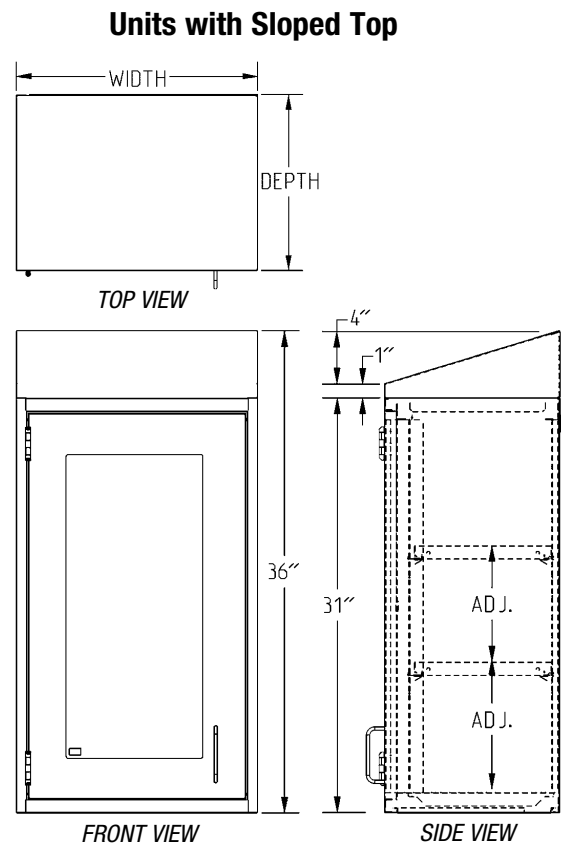
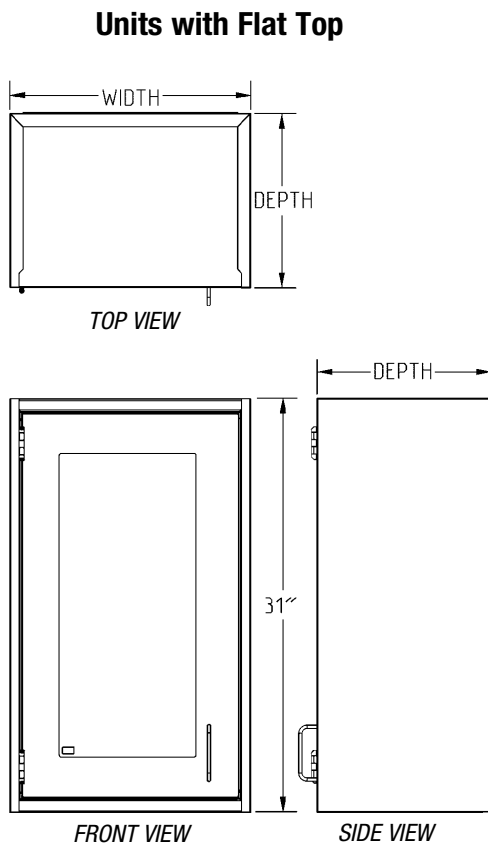

Units with Flat Top						Units with Sloped Top								
depth		width		height		weight		model #	height		weight		model #	
in.	mm	in.	mm	in.	mm	lbs.	kg		in.	mm	lbs.	kg		
13"	330	18"	457	left-swing	31"	787	166	75.3	SSC-WCGHL-1318	36"	914	186	84.4	SSC-WCGHLST-1318
13"	330	18"	457	right-swing	31"	787	166	75.3	SSC-WCGHR-1318	36"	914	186	84.4	SSC-WCGHRST-1318
13"	330	24"	610	left-swing	31"	787	172	78.0	SSC-WCGHL-1324	36"	914	192	87.1	SSC-WCGHLST-1324
13"	330	24"	610	right-swing	31"	787	172	78.0	SSC-WCGHR-1324	36"	914	192	87.1	SSC-WCGHRST-1324
13"	330	30"	762	double	31"	787	184	83.4	SSC-WCGH-1330	36"	914	204	92.5	SSC-WCGHST-1330
13"	330	36"	914	double	31"	787	184	83.4	SSC-WCGH-1336	36"	914	222	100.7	SSC-WCGHST-1336
13"	330	48"	1219	double	31"	787	202	91.6	SSC-WCGH-1348	36"	914	258	117.0	SSC-WCGHST-1348
16"	406	18"	457	left-swing	31"	787	172	78.0	SSC-WCGHL-1618	36"	914	192	87.1	SSC-WCGHLST-1618
16"	406	18"	457	right-swing	31"	787	172	78.0	SSC-WCGHR-1618	36"	914	192	87.1	SSC-WCGHRST-1618
16"	406	24"	457	left-swing	31"	787	178	80.7	SSC-WCGHL-1624	36"	914	198	89.8	SSC-WCGHLST-1618
16"	406	24"	457	right-swing	31"	787	178	80.7	SSC-WCGHR-1624	36"	914	198	89.8	SSC-WCGHRST-1618
16"	406	30"	762	double	31"	787	190	86.2	SSC-WCGH-1630	36"	914	210	95.2	SSC-WCGHST-1630
16"	406	36"	914	double	31"	787	196	88.9	SSC-WCGH-1636	36"	914	216	98.0	SSC-WCGHST-1636
16"	406	48"	1219	double	31"	787	214	97.1	SSC-WCGH-1648	36"	914	264	119.7	SSC-WCGHST-1648

**EAGLE GROUP**

100 Industrial Boulevard, Clayton, DE 19938-8903 USA  
 Phone: 302-653-3000 or 800-441-8440 • Fax: 302-653-2065  
 www.eaglegrp.com • www.eaglehmc.com

Printed in U.S.A.  
 ©2021 by Eagle Group  
 Rev. 11/21

Spec sheets available for viewing, printing or downloading from our online literature library at [www.eaglegrp.com](http://www.eaglegrp.com)

Although every attempt has been made to ensure the accuracy of the information provided, we cannot be held responsible for typographical or printing errors. Information and specifications are subject to change without notice. Please confirm at time of order.