



Profit from the Eagle Advantage®

Specification Sheet

Short Form Specifications

Eagle Corner Base Cabinet, model _____.
All stainless steel type 304 enclosed cabinet. 22"-deep. 35" height.
Available with open front or with left- or right-swing door. 4" toe kick, leveling feet, removable back panel, and adjustable shelf. Doors, when provided, are inset double-panel construction, mounted with five-knuckle hinges and provided with 4" wire pull handle and roller catch. Designed and tested to the SEFA 8 Metal Casework recommended practices.

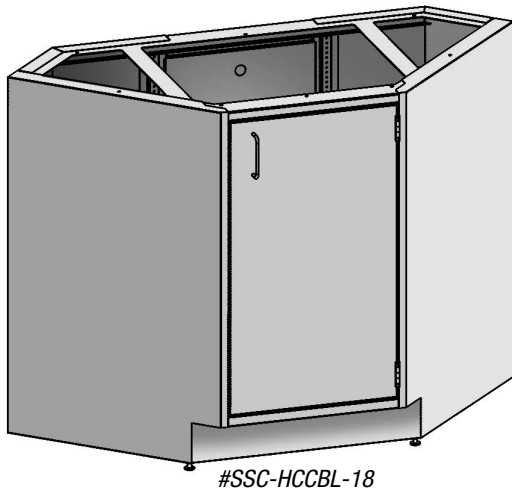

#SSC-HCCBL-18

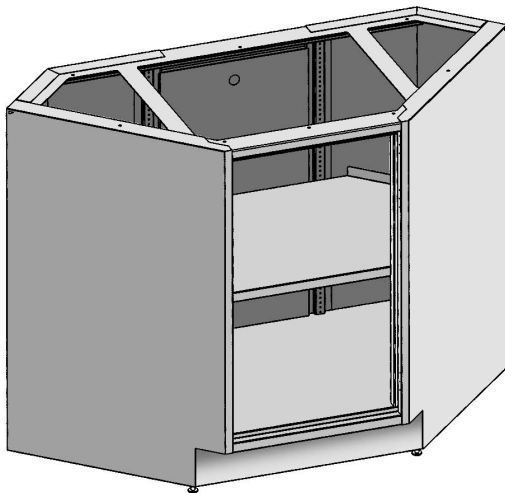

#SSC-HCOB-18

Item No.:	_____
Project No.:	_____
S.I.S. No.:	_____

Standing Height Corner Base Cabinets

MODELS:

- SSC-HCOB-18
- SSC-HCCBL-18
- SSC-HCCBR-18

Design and Construction Features

- Type 304 stainless steel construction.
- One intermediate shelf, adjustable on 1/2" increments.
- Mates with 22" (559mm) front-to-back cabinets.
- 35" (889mm) height.
- Available with open front or with full-height hinged doors.
- Units with doors offered with single left- or right-swing door.
- Doors are double-panel inset construction with five-knuckle hinges, 4" wire pull, and roller catch.
- Provided with leveling feet accessible from inside the cabinet.

Options / Accessories

- Door lock
- Additional shelves
- Custom door pulls

Certifications / Approvals



SEFA 8 Metal Casework

EAGLE GROUP

100 Industrial Boulevard
Clayton, DE 19938-8903 USA

Phone: 302-653-3000 • 800-441-8440

Fax: 302-653-2065

www.eaglegrp.com • www.eaglemhc.com

For custom configuration or fabrication needs, contact our SpecFAB® Division.

Phone: 302-653-3000 • Fax: 302-653-2065 • e-mail: quotes@eaglegrp.com

EG03.07 Rev. 10/21

Spec sheets available for viewing, printing or downloading from our online literature library at www.eaglegrp.com

Eagle Foodservice Equipment, Eagle MHC, and SpecFAB® are divisions of Eagle Group. ©2021 by the Eagle Group

Item No.: _____
Project No.: _____
S.I.S. No.: _____

Standing Height Corner Base Cabinets

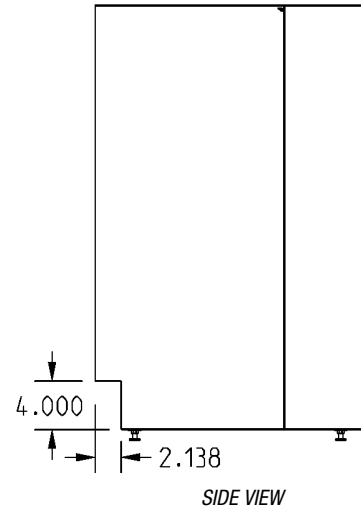
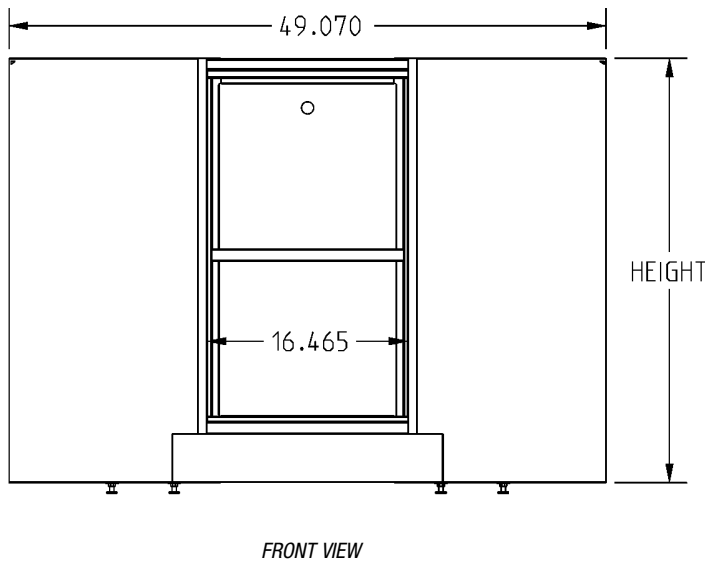
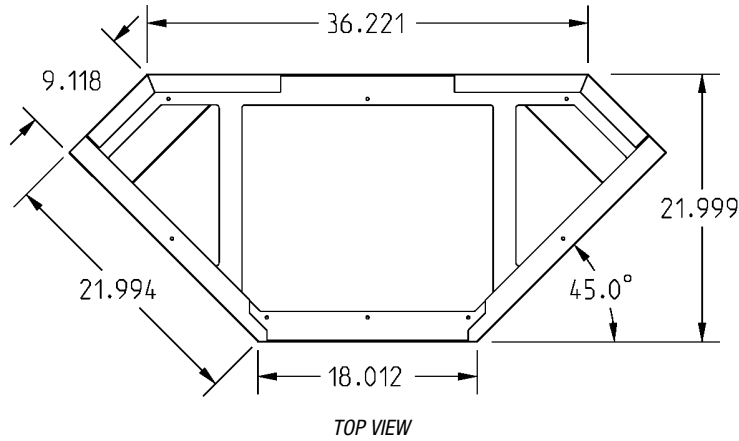

35" Standing Height

description	weight		model #
	lbs.	kg	
open front	142	64.4	SSC-HCOB-18
with full-height left door	149	67.6	SSC-HCCBL-18
with full-height right door	149	67.6	SSC-HCCBR-18

EAGLE GROUP
100 Industrial Boulevard, Clayton, DE 19938-8903 USA
Phone: 302-653-3000 or 800-441-8440 • Fax: 302-653-2065
www.eaglegrp.com • www.eaglemhc.com

Printed in U.S.A.
©2021 by Eagle Group
Rev. 10/21

Spec sheets available for viewing, printing or downloading from our online literature library at www.eaglegrp.com

Although every attempt has been made to ensure the accuracy of the information provided, we cannot be held responsible for typographical or printing errors. Information and specifications are subject to change without notice. Please confirm at time of order.