



Profit from the Eagle Advantage®

Specification Sheet

Short Form Specifications

Eagle Q-LEVER® Cantilever Add-On Shelving, model _____, 5-Tier add-on units feature one 76"-high upright, four wire shelves, and bottom dunnage shelf. Maximum accessibility and productivity. No wall bolting required. Upright utilizes adjustment in 2" increments without the use of tools. Shelves offered with Valu-Master® gray or Valu-Gard® green epoxy finish. Valu-Master® gray epoxy on upright.

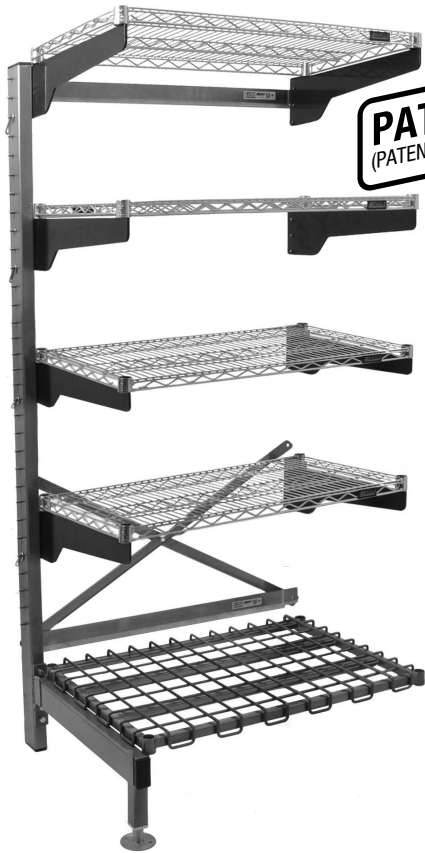

PATENTED
(PATENT #10,159,339)

Options / Accessories

- Wall Grids
- Hanger Rails
- Supply Bins
- Storage Baskets
- 36", 56", 66", or 86" optional height.

EAGLE GROUP

100 Industrial Boulevard
Clayton, DE 19938-8903 USA

Phone: 302-653-3000 • 800-441-8440

Fax: 302-653-2065

www.eaglegrp.com • www.eaglemhc.com

For custom configuration or fabrication needs, contact our SpecFAB® Division.

Phone: 302-653-3000 • Fax: 302-653-2065 • e-mail: quotes@eaglegrp.com

Item No.: _____
 Project No.: _____
 S.I.S. No.: _____

Q-LEVER® Cantilever Shelving— 5-Tier Add-On Units with Bottom Dunnage Shelf, 76" Height

MODELS:

- | | | | |
|-----------------------------------|-----------------------------------|-----------------------------------|-----------------------------------|
| <input type="checkbox"/> Q1824*5D | <input type="checkbox"/> Q2124*5D | <input type="checkbox"/> Q2424*5D | <input type="checkbox"/> Q3030*5D |
| <input type="checkbox"/> Q1830*5D | <input type="checkbox"/> Q2130*5D | <input type="checkbox"/> Q2430*5D | <input type="checkbox"/> Q3036*5D |
| <input type="checkbox"/> Q1836*5D | <input type="checkbox"/> Q2136*5D | <input type="checkbox"/> Q2436*5D | <input type="checkbox"/> Q3042*5D |
| <input type="checkbox"/> Q1842*5D | <input type="checkbox"/> Q2142*5D | <input type="checkbox"/> Q2442*5D | <input type="checkbox"/> Q3048*5D |
| <input type="checkbox"/> Q1848*5D | <input type="checkbox"/> Q2148*5D | <input type="checkbox"/> Q2448*5D | <input type="checkbox"/> Q3054*5D |
| <input type="checkbox"/> Q1854*5D | <input type="checkbox"/> Q2154*5D | <input type="checkbox"/> Q2454*5D | <input type="checkbox"/> Q3060*5D |
| <input type="checkbox"/> Q1860*5D | <input type="checkbox"/> Q2160*5D | <input type="checkbox"/> Q2460*5D | <input type="checkbox"/> Q3066*5D |
| <input type="checkbox"/> Q1866*5D | <input type="checkbox"/> Q2166*5D | <input type="checkbox"/> Q2466*5D | <input type="checkbox"/> Q3072*5D |
| <input type="checkbox"/> Q1872*5D | <input type="checkbox"/> Q2172*5D | <input type="checkbox"/> Q2472*5D | |

* See charts on back page for complete model numbers.

Design & Construction Features

- Includes one 76" upright, two braces, four wire shelves, four pairs of brackets, one dunnage shelf, X-brace assembly, and hardware.
- Cantilevered design improves accessibility and productivity.
- Wall bolting not required.
- Upright utilizes 2" adjustment for shelf and accessory spacing.
- Shelves and accessories can be easily adjusted without tools
- Shelves can be added to the left or right of an existing unit.
- Sizing available:
 - Widths: 18"; 21"; 24"; 30"
 - Lengths: 24"; 30"; 36"; 42"; 48"; 54"; 60"
 - Height (standard): 76"
- Choice of Valu-Master® gray or Valu-Gard® green epoxy finish on the shelves.
- Valu-Master® gray epoxy finish on upright.

Certifications / Approvals



AutoQuotes



EG01.59D Rev. 04/22

Spec sheets available for viewing, printing or downloading from our online literature library at www.eaglegrp.com

Eagle Foodservice Equipment, Eagle MHC, and SpecFAB® are divisions of Eagle Group. ©2022 by the Eagle Group

Item No.: _____
Project No.: _____
S.I.S. No.: _____

Q-LEVER® Shelving—5-Tier Add-Ons with Dunnage, 76" Height

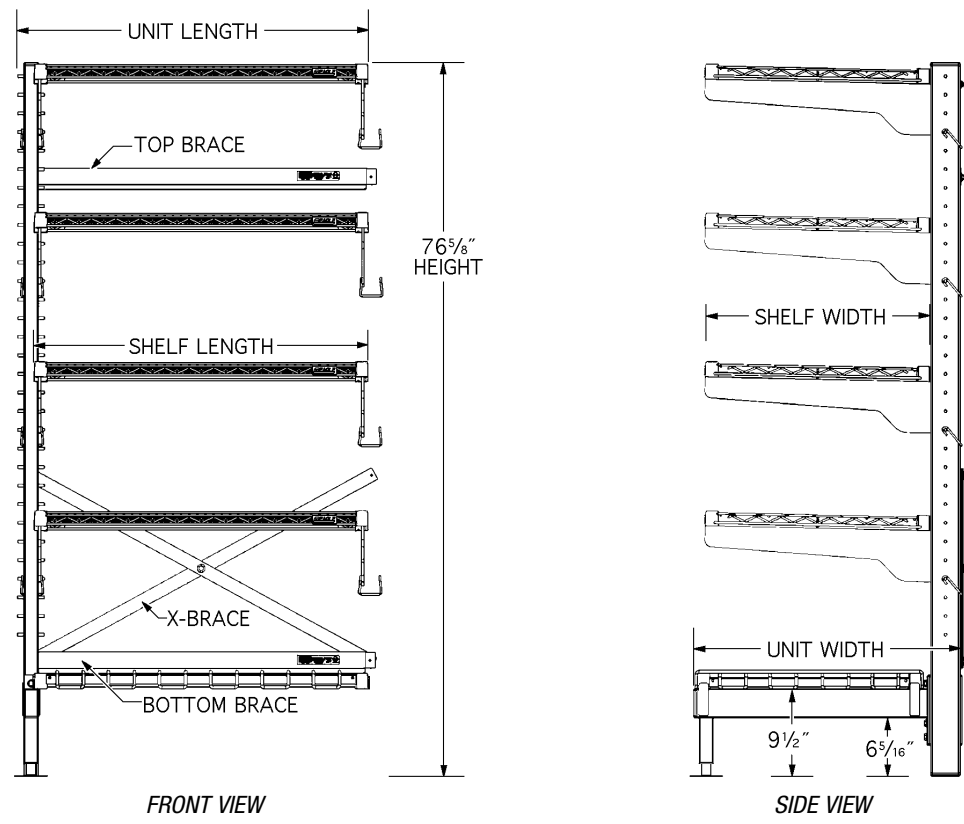

shelf length	unit** length	...WITH 18" (457mm)-WIDE SHELVES *		...WITH 21" (533mm)-WIDE SHELVES *		...WITH 24" (610mm)-WIDE SHELVES *		...WITH 30" (762mm)-WIDE SHELVES *			
		Shelves with Valu-Master® finish	Shelves with Valu-Gard® finish	Shelves with Valu-Master® finish	Shelves with Valu-Gard® finish	Shelves with Valu-Master® finish	Shelves with Valu-Gard® finish	Shelves with Valu-Master® finish	Shelves with Valu-Gard® finish		
24"	610	25 1/2"	648	Q1824V76A-5D	Q1824VG76A-5D	Q2124V76A-5D	Q2124VG76A-5D	Q2424V76A-5D	Q2424VG76A-5D	-	-
30"	762	31 1/2"	800	Q1830V76A-5D	Q1830VG76A-5D	Q2130V76A-5D	Q2130VG76A-5D	Q2430V76A-5D	Q2430VG76A-5D	Q3030V76A-5D	Q3030VG76A-5D
36"	914	37 1/2"	953	Q1836V76A-5D	Q1836VG76A-5D	Q2136V76A-5D	Q2136VG76A-5D	Q2436V76A-5D	Q2436VG76A-5D	Q3036V76A-5D	Q3036VG76A-5D
42"	1067	43 1/2"	1105	Q1842V76A-5D	Q1842VG76A-5D	Q2142V76A-5D	Q2142VG76A-5D	Q2442V76A-5D	Q2442VG76A-5D	Q3042V76A-5D	Q3042VG76A-5D
48"	1219	49 1/2"	1257	Q1848V76A-5D	Q1848VG76A-5D	Q2148V76A-5D	Q2148VG76A-5D	Q2448V76A-5D	Q2448VG76A-5D	Q3048V76A-5D	Q3048VG76A-5D
54"	1372	55 1/2"	1410	Q1854V76A-5D	Q1854VG76A-5D	Q2154V76A-5D	Q2154VG76A-5D	Q2454V76A-5D	Q2454VG76A-5D	Q3054V76A-5D	Q3054VG76A-5D
60"	1524	61 1/2"	1562	Q1860V76A-5D	Q1860VG76A-5D	Q2160V76A-5D	Q2160VG76A-5D	Q2460V76A-5D	Q2460VG76A-5D	Q3060V76A-5D	Q3060VG76A-5D
66"	1676	67 1/2"	1715	Q1866V76A-5D	Q1866VG76A-5D	Q2166V76A-5D	Q2166VG76A-5D	Q2466V76A-5D	Q2466VG76A-5D	Q3066V76A-5D	Q3066VG76A-5D
72"	1829	73 1/2"	1867	Q1872V76A-5D	Q1872VG76A-5D	Q2172V76A-5D	Q2172VG76A-5D	Q2472V76A-5D	Q2472VG76A-5D	Q3072V76A-5D	Q3072VG76A-5D

* For unit width, add 5 inches to shelf width.
** Dimensions are nominal.