



Profit from the Eagle Advantage®

# Specification Sheet

## Short Form Specifications

Eagle Laboratory Wall Shelves, model \_\_\_\_\_: Three shelf modular system with stainless steel 16 gauge 1" tubular uprights with laser cut notches for shelf attachment and mounting. 16 gauge type 304 stainless shelves with 1/4" rear upturn, 4 1/2" upturned bookends, and center hat channel. Shelves attached with triple hooks per end adjustable on 1/2" centerlines. Uprights are 36 1/2" tall. Shelves are available in 12", 15", and 18" depths and 24", 30", 36", 48", 60", and 72" lengths. Optional wire ledge is available. Designed to meet the SEFA recommended practices.



#LS1236-36-3L  
laboratory wall shelf unit

Item No.: \_\_\_\_\_  
Project No.: \_\_\_\_\_  
S.I.S. No.: \_\_\_\_\_

## Laboratory Wall Shelves with Upturned Bookends

### MODELS:

- LS1230-36-3       LS1230-36-3L
- LS1236-36-3       LS1236-36-3L
- LS1248-36-3       LS1248-36-3L
- LS1260-36-3       LS1260-36-3L
- LS1272-36-3       LS1272-36-3L
- LS1530-36-3       LS1530-36-3L
- LS1536-36-3       LS1536-36-3L
- LS1548-36-3       LS1548-36-3L
- LS1560-36-3       LS1560-36-3L
- LS1572-36-3       LS1572-36-3L
- LS1830-36-3       LS1830-36-3L
- LS1836-36-3       LS1836-36-3L
- LS1848-36-3       LS1848-36-3L
- LS1860-36-3       LS1860-36-3L
- LS1872-36-3       LS1872-36-3L

### Design & Construction Features:

- 36 1/2" (927mm) tall, 1" (25mm) square, 16 gauge stainless steel tubular uprights with laser-cut notches for shelves
- 16 gauge type 304 stainless steel shelves with 1/4" rear upturn, 4 1/2" (114mm) bookends, and center hat channel
- Three shelves, adjustable on 1/2" (32mm) centerlines, attach with triple hooks per end
- Available in 12", 15", and 18" (305, 381, and 457mm) depths
- Available in lengths ranging from 24" to 72" (610 to 1828mm)
- Offered with or without front wire ledge.
- 150-lb. (68.1 kg) weight capacity.

### Options / Accessories

- 1/4" diameter wire ledge
- Additional shelves
- Custom sizing per application

### Certifications / Approvals



SEFA 8 Metal Casework

### EAGLE GROUP

100 Industrial Boulevard, Clayton, DE 19938-8903 USA  
Phone: 302-653-3000 • 800-441-8440 • Fax: 302-653-2065  
www.eaglegrp.com  
www.eaglemhc.com

For custom configuration or fabrication needs, contact our **SpecFAB®** Division.  
Phone: 302-653-3000 • Fax: 302-653-2065 • e-mail: quotes@eaglegrp.com

EG03.80 Rev. 01/24

Spec sheets available for viewing, printing or downloading from our online literature library at our websites



Profit from the Eagle Advantage®

Item No.: \_\_\_\_\_  
 Project No.: \_\_\_\_\_  
 S.I.S. No.: \_\_\_\_\_

# Laboratory Wall Shelves with Upturned Bookends

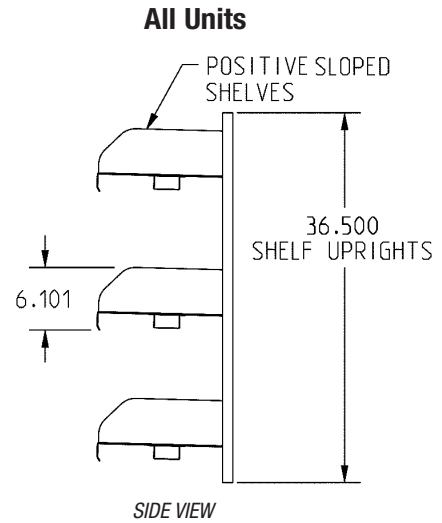
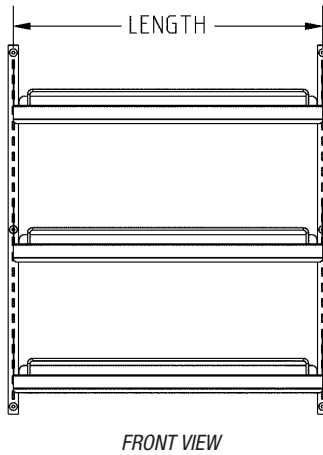
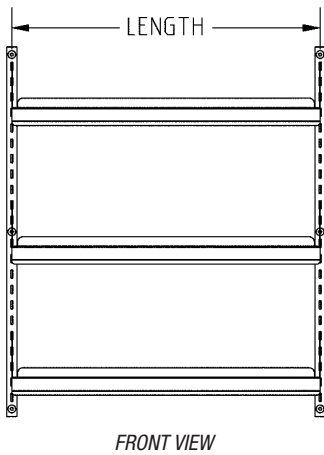
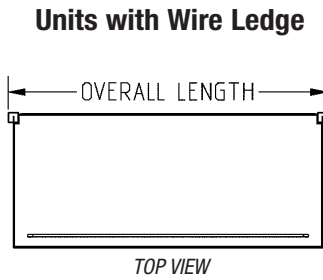
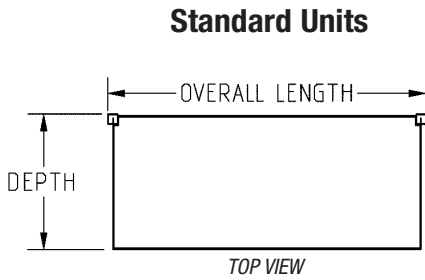

shelf depth		shelf length		O.A. unit length		unit * weight		COMPLETE UNITS		COMPONENTS	
in.	mm	in.	mm	in.	mm	lbs.	kg	with Standard Shelves model #	with Front Wire Ledge on Shelves model #	Single Shelf model #	Single Shelf with Front Wire Ledge model #
12"	305	30"	762	31"	787	38	17.2	LS1230-36-3	LS1230-36-3L	LS1230	LS1230-L
12"	305	36"	914	37"	939	43	19.5	LS1236-36-3	LS1236-36-3L	LS1236	LS1236-L
12"	305	48"	1219	49"	1244	52	23.6	LS1248-36-3	LS1248-36-3L	LS1248	LS1248-L
12"	305	60"	1524	61"	1549	62	28.1	LS1260-36-3	LS1260-36-3L	LS1260	LS1260-L
12"	305	72"	1828	73"	1854	71	32.2	LS1272-36-3	LS1272-36-3L	LS1272	LS1272-L
15"	381	30"	762	31"	787	44	20.0	LS1530-36-3	LS1530-36-3L	LS1530	LS1530-L
15"	381	36"	914	37"	939	50	22.7	LS1536-36-3	LS1536-36-3L	LS1536	LS1536-L
15"	381	48"	1219	49"	1244	61	27.7	LS1548-36-3	LS1548-36-3L	LS1548	LS1548-L
15"	381	60"	1524	61"	1549	72	32.7	LS1560-36-3	LS1560-36-3L	LS1560	LS1560-L
15"	381	72"	1828	73"	1854	83	37.6	LS1572-36-3	LS1572-36-3L	LS1572	LS1572-L
18"	457	30"	762	31"	787	51	23.1	LS1830-36-3	LS1830-36-3L	LS1830	LS1830-L
18"	457	36"	914	37"	939	57	25.9	LS1836-36-3	LS1836-36-3L	LS1836	LS1836-L
18"	457	48"	1219	49"	1244	70	31.8	LS1848-36-3	LS1848-36-3L	LS1848	LS1848-L
18"	457	60"	1524	61"	1549	83	37.6	LS1860-36-3	LS1860-36-3L	LS1860	LS1860-L
18"	457	72"	1828	73"	1854	97	44.0	LS1872-36-3	LS1872-36-3L	LS1872	LS1872-L

**Uprights**  
 These uprights can be used between two shelves. Sold individually.

height		model #
in.	mm	
18"	457	LS18VU
24"	457	LS24VU
30"	457	LS30VU
36"	457	LS36VU
42"	457	LS42VU
48"	1219	LS48VU

**!**  
 Shelf not to exceed a maximum of 150 lbs. evenly distributed

\* Weight is for the complete kit consisting of three shelves and two uprights.

**EAGLE GROUP**  
 100 Industrial Boulevard, Clayton, DE 19938-8903 USA  
 Phone: 302-653-3000 or 800-441-8440 • Fax: 302-653-2065  
 www.eaglegrp.com • www.eaglehmc.com

Printed in U.S.A.  
 ©2024 by Eagle Group

Rev. 01/24

Spec sheets available for viewing, printing or downloading from our online literature library at our websites

Although every attempt has been made to ensure the accuracy of the information provided, we cannot be held responsible for typographical or printing errors. Information and specifications are subject to change without notice. Please confirm at time of order.



Profit from the Eagle Advantage®

# Specification Sheet

## Short Form Specifications

Eagle Laboratory Wall Shelves, model \_\_\_\_\_.  
Three shelf modular system with stainless steel 16 gauge 1" tubular uprights with laser cut notches for shelf attachment and mounting. 16 gauge type 304 stainless shelves with 1/4" rear upturn, 4 1/2" downturned bookends, and center hat channel. Shelves attached with triple hooks per end adjustable on 1 1/2" centerlines. Uprights are 36 1/2" tall. Shelves are available in 12", 15", and 18" depths and 24", 30", 36", 48", 60", and 72" lengths. Optional wire ledge is available. Designed to meet the SEFA recommended practices.



#LSD1236-36-3L  
laboratory wall shelf unit

Item No.: \_\_\_\_\_  
Project No.: \_\_\_\_\_  
S.I.S. No.: \_\_\_\_\_

## Laboratory Wall Shelves with Downturned Bookends

### MODELS:

- LSD1230-36-3     LSD1230-36-3L
- LSD1236-36-3     LSD1236-36-3L
- LSD1248-36-3     LSD1248-36-3L
- LSD1260-36-3     LSD1260-36-3L
- LSD1272-36-3     LSD1272-36-3L
- LSD1530-36-3     LSD1530-36-3L
- LSD1536-36-3     LSD1536-36-3L
- LSD1548-36-3     LSD1548-36-3L
- LSD1560-36-3     LSD1560-36-3L
- LSD1572-36-3     LSD1572-36-3L
- LSD1830-36-3     LSD1830-36-3L
- LSD1836-36-3     LSD1836-36-3L
- LSD1848-36-3     LSD1848-36-3L
- LSD1860-36-3     LSD1860-36-3L
- LSD1872-36-3     LSD1872-36-3L

### Design & Construction Features:

- 36 1/2" (927mm) tall, 1" (25mm) square, 16 gauge stainless steel tubular uprights with laser-cut notches for shelves
- 16 gauge type 304 stainless steel shelves with 1/4" rear upturn, 4 1/2" (114mm) downturned bookends, and center hat channel
- Three shelves, adjustable on 1 1/2" (32mm) centerlines, attach with triple hooks per end
- Available in 12", 15", and 18" (305, 381, and 457mm) depths
- Available in lengths ranging from 24" to 72" (610 to 1828mm)
- Offered with or without front wire ledge.
- 150-lb. (68.1 kg) weight capacity.

### Options / Accessories

- 1/4" diameter wire ledge
- Additional shelves
- Custom sizing per application

### Certifications / Approvals



SEFA 8 Metal Casework

### EAGLE GROUP

100 Industrial Boulevard, Clayton, DE 19938-8903 USA  
Phone: 302-653-3000 • 800-441-8440 • Fax: 302-653-2065  
www.eaglegrp.com  
www.eaglemhc.com

For custom configuration or fabrication needs, contact our **SpecFAB® Division**.  
Phone: 302-653-3000 • Fax: 302-653-2065 • e-mail: quotes@eaglegrp.com

EG03.81 Rev. 01/24

**Spec sheets available for viewing, printing or downloading from our online literature library at our websites**

Item No.: \_\_\_\_\_  
 Project No.: \_\_\_\_\_  
 S.I.S. No.: \_\_\_\_\_

## Laboratory Wall Shelves with Downturned Bookends

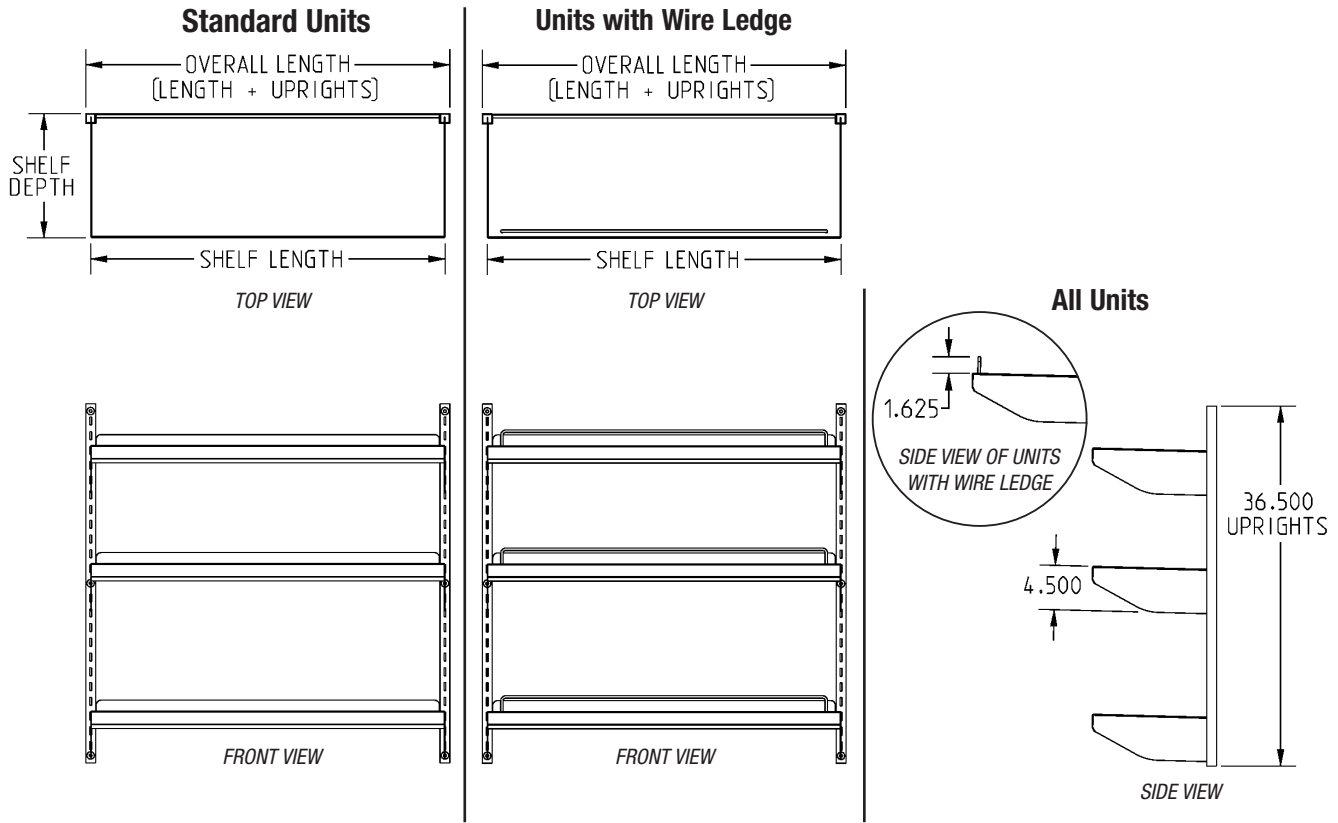

COMPLETE UNITS										COMPONENTS					
shelf depth		shelf length		O.A. unit length		unit * weight		with Standard Shelves	with Front Wire Ledge on Shelves	Single Shelf	Single Shelf with Front Wire Ledge	Uprights			
in.	mm	in.	mm	in.	mm	lbs.	kg	model #	model #	model #	model #	height	in.	mm	model #
12"	305	30"	762	31"	787	38	17.2	LSD1230-36-3	LSD1230-36-3L	LSD1230	LSD1230-L	18"	457		LS18VU
12"	305	36"	914	37"	939	43	19.5	LSD1236-36-3	LSD1236-36-3L	LSD1236	LSD1236-L	24"	457		LS24VU
12"	305	48"	1219	49"	1244	52	23.6	LSD1248-36-3	LSD1248-36-3L	LSD1248	LSD1248-L	30"	457		LS30VU
12"	305	60"	1524	61"	1549	62	28.1	LSD1260-36-3	LSD1260-36-3L	LSD1260	LSD1260-L	36"	457		LS36VU
12"	305	72"	1828	73"	1854	71	32.2	LSD1272-36-3	LSD1272-36-3L	LSD1272	LSD1272-L	42"	457		LS42VU
15"	381	30"	762	31"	787	44	20.0	LSD1530-36-3	LSD1530-36-3L	LSD1530	LSD1530-L	48"	1219		LS48VU
15"	381	36"	914	37"	939	50	22.7	LSD1536-36-3	LSD1536-36-3L	LSD1536	LSD1536-L				
15"	381	48"	1219	49"	1244	61	27.7	LSD1548-36-3	LSD1548-36-3L	LSD1548	LSD1548-L				
15"	381	60"	1524	61"	1549	72	32.7	LSD1560-36-3	LSD1560-36-3L	LSD1560	LSD1560-L				
15"	381	72"	1828	73"	1854	83	37.6	LSD1572-36-3	LSD1572-36-3L	LSD1572	LSD1572-L				
18"	457	30"	762	31"	787	51	23.1	LSD1830-36-3	LSD1830-36-3L	LSD1830	LSD1830-L				
18"	457	36"	914	37"	939	57	25.9	LSD1836-36-3	LSD1836-36-3L	LSD1836	LSD1836-L				
18"	457	48"	1219	49"	1244	70	31.8	LSD1848-36-3	LSD1848-36-3L	LSD1848	LSD1848-L				
18"	457	60"	1524	61"	1549	83	37.6	LSD1860-36-3	LSD1860-36-3L	LSD1860	LSD1860-L				
18"	457	72"	1828	73"	1854	97	44.0	LSD1872-36-3	LSD1872-36-3L	LSD1872	LSD1872-L				

\* Weight is for the complete kit consisting of three shelves and two uprights.

  
 Shelf not to exceed a maximum of 150 lbs. evenly distributed

**EAGLE GROUP**  
 100 Industrial Boulevard, Clayton, DE 19938-8903 USA  
 Phone: 302-653-3000 or 800-441-8440 • Fax: 302-653-2065  
 www.eaglegrp.com • www.eaglehmc.com

Printed in U.S.A.  
 ©2024 by Eagle Group

Rev. 01/24

Spec sheets available for viewing, printing or downloading from our online literature library at our websites

Although every attempt has been made to ensure the accuracy of the information provided, we cannot be held responsible for typographical or printing errors. Information and specifications are subject to change without notice. Please confirm at time of order.