

Foodservice Equipment • Material Handling, Healthcare & Cleanroom Equipment • Retail Display

Short Form Specifications

Eagle Spec-Master® FFN Series Flush Front Sink, model _____.
Drainboards, sink bowl partitions, front panel, sink bowl exterior wrapper, and backsplash to be 14 gauge type 304 stainless steel. Sinks compartments to have 3/4" inside radii. 1 1/2" stainless steel tubular legs with stainless steel gussets, crossrails, and stainless steel adjustable bullet feet.

Spec-Master® FFN Series Flush Front Sinks



three-compartment sink shown

Optional Accessories	Model #	Qty.
Faucet		
Prerinse faucet		
Lever drain		
Lever drain with overflow		
Twist handle drains		
Overflow hole		
Undershelf		
Flanged feet		

- Full front and backsplash are 14 gauge stainless steel.
- 14 gauge double drainboards, rolled rims and sink bowl partitions.
- 10" (254mm)-high backsplash with 1" (25mm) downturn at rear.
- Sink compartments feature 3/4" (19mm) covered inside radii.
- Basket-type waste drain fits 3 1/2" (89mm) opening and features 1 1/2" (38mm) outlet.
- Legs* are located directly under sink bowls, providing increased stability and maximum weight support.
- All-welded base constructed of 1 5/8" (41mm)-diameter tubular stainless steel.
- Adjustable stainless steel bullet feet.
- 14" (356mm) water level.
- Swirl-away drainage.

* For units with 30" (762mm)-long drainboards, additional legs are located under each drainboard.

For custom options... please consult the factory.



Spec sheets available for viewing, printing or downloading from our online literature library at www.eaglegrp.com

Spec-Master® FFN Series Flush Front Sinks

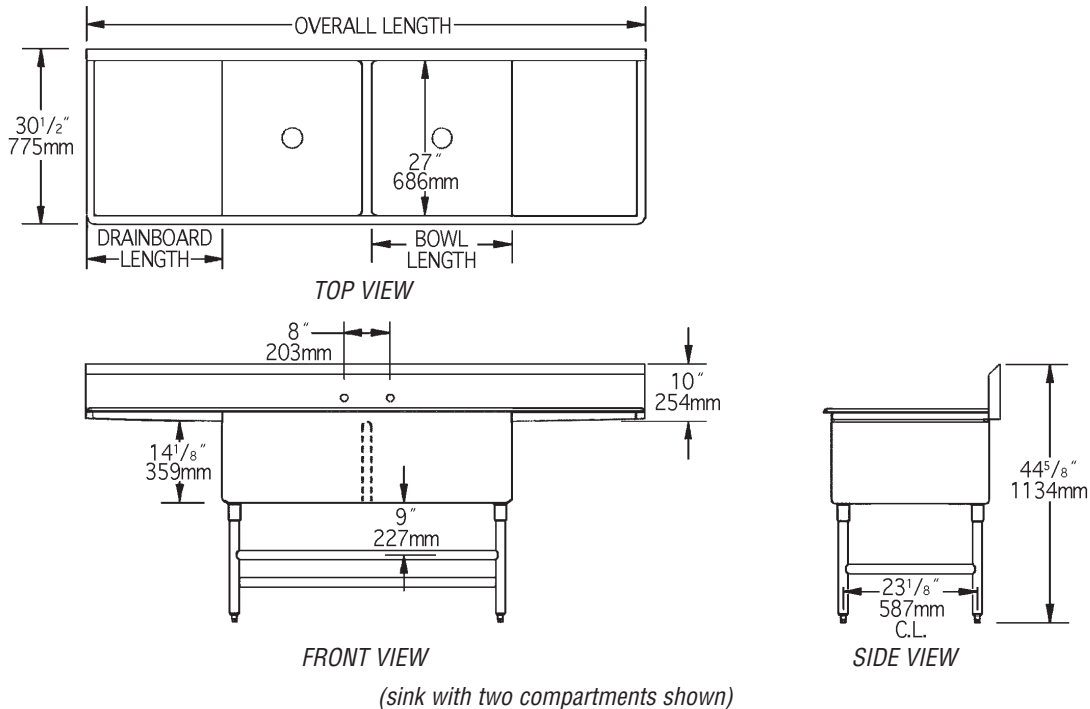

Sinks with Two Compartments

model #	BOWL DIMENSIONS		DRAINBOARDS length	OVERALL DIMENSIONS				
	width	length		width	length			
	in.	mm	in.	mm	in.	mm		
FFN2736-2-24-14/3	27"	686	18"	457	24"	610	30 1/2" 775	85 5/8" 2175
FFN2736-2-30-14/3	27"	686	18"	457	30"	762	30 1/2" 775	97 5/8" 2480
FFN2740-2-24-14/3	27"	686	20"	508	24"	610	30 1/2" 775	89 5/8" 2277
FFN2740-2-30-14/3	27"	686	20"	508	30"	762	30 1/2" 775	101 5/8" 2581
FFN2748-2-24-14/3	27"	686	24"	610	24"	610	30 1/2" 775	97 5/8" 2480
FFN2748-2-30-14/3	27"	686	24"	610	30"	762	30 1/2" 775	109 5/8" 2785
FFN2760-2-24-14/3	27"	686	30"	762	24"	610	30 1/2" 775	109 5/8" 2785
FFN2760-2-30-14/3	27"	686	30"	762	30"	762	30 1/2" 775	121 5/8" 3089

Sinks with Three Compartments*

model #	BOWL DIMENSIONS		DRAINBOARDS length	OVERALL DIMENSIONS				
	width	length		width	length			
	in.	mm	in.	mm	in.	mm		
FFN2754-3-24-14/3	27"	686	18"	457	24"	610	30 1/2" 775	105 1/4" 2673
FFN2754-3-30-14/3	27"	686	18"	457	30"	762	30 1/2" 775	117 1/4" 2978
FFN2760-3-24-14/3	27"	686	20"	508	24"	610	30 1/2" 775	111 1/4" 2826
FFN2760-3-30-14/3	27"	686	20"	508	30"	762	30 1/2" 775	123 1/4" 3131
FFN2772-3-24-14/3	27"	686	24"	610	24"	610	30 1/2" 775	123 1/4" 3131
FFN2772-3-30-14/3	27"	686	24"	610	30"	762	30 1/2" 775	135 1/4" 3435
FFN2790-3-24-14/3	27"	686	30"	762	24"	610	30 1/2" 775	141 1/4" 3588
FFN2790-3-30-14/3	27"	686	30"	762	30"	762	30 1/2" 775	153 1/4" 3893

* Three-compartment sinks feature two sets of faucet holes.