



Profit from the Eagle Advantage®

Specification Sheet

Short Form Specifications

Eagle LIFESTOR® Master Trak® Overhead Trak Polymer Storage System to consist of 2" x 2" x 1/4" aluminum channel overhead track. Mobile units to consist of 14 gauge stainless steel dolly frame with four 5"-diameter rigid poly casters, four 1"-thick gray PVC corner bumpers, and four 16 gauge stainless steel posts and hardware. Stationary units on each end consist of 16 gauge type 304 stainless steel posts, stainless steel footplates and hardware. All shelves sold separately.



LIFESTOR® Master Trak® Overhead Polymer System shown with optional enclosure panel

Options / Accessories *

- Dividers
- Ledges
- Enclosure panels
- Tote slide systems

* See Spec Sheet #EG01.12D for more information on options and accessories for LIFESTOR® Master Trak®.

Additional notes on back page.

EAGLE GROUP
100 Industrial Boulevard, Clayton, DE 19938-8903 USA
Phone: 302-653-3000 • Fax: 302-653-2065
www.eaglegrp.com

Foodservice Division: Phone 800-441-8440
MHC/Retail Display Divisions: Phone 800-637-5100

For custom configuration or fabrication needs, contact our **SpecFAB® Division**.
Phone: 302-653-3000 • Fax: 302-653-2065 • e-mail: quotes@eaglegrp.com

Spec sheets available for viewing, printing or downloading from our online literature library at www.eaglegrp.com

Eagle Foodservice Equipment, Eagle MHC, SpecFAB®, and Retail Display are divisions of Eagle Group. ©2013 by the Eagle Group

Item No.:	_____
Project No.:	_____
S.I.S. No.:	_____

LIFESTOR® Master Trak® Overhead Track Polymer Storage System

MODELS:

- LEP74-S
- LLMUK23*
- LLMUK18*
- LOHT-*

* See charts on back for complete model numbers.

Design and Construction Features

- Features stationary units, mobile unit, and overhead track (listed below).
- Maximizes storage in a minimum of space.
- Quick and easy assembly.
- All units include necessary hardware.

Stationary Unit

- Four 74" (1880mm) 16 gauge type 304 stainless steel posts.
- Triangular stainless steel foot plates.
- Positioned on each end, and also serve as a mid unit.
- A maximum of three mobile units and 36" (914mm) aisle space is allowed before a mid stationary unit is necessary.
- Stationary units must be bolted to the floor.

Mobile Unit Kits

- 14 gauge stainless steel dolly frame that features four 5" (127mm) rigid poly casters and four 1" (25mm)-thick gray PVC corner bumpers.
- Four 74" (1880mm) 16 gauge type 304 stainless steel posts.

Overhead Track Units

- Available in 6' to 21' (1829 to 6401mm) lengths.
- Front and rear 2" x 2" x 1/4" (51 x 51 x 6mm) aluminum channels for lengths up to 9' (2743mm). Any unit 10' (3048mm) or longer will have multiple track sections.
- Each section will be joined with a 2" x 2" (51 x 51mm) 14 gauge stainless steel connector and necessary hardware to join the tracks.

LIFESTOR® Polymer Shelving (sold separately)

- Smooth polymer shelf surfaces for ease of product removal.
- Solid or louvered shelves available (see spec sheet #EG01.12A).
- Removable shelf mats are dishwasher-safe for sanitation.
- Makes cleaning easier with safe access to all units and shelf contents.
- Standard with antimicrobial agent MICROGARD®. For more information, contact your customer service representative.

Certifications / Approvals



AUTOQUOTES





Item No.: _____
 Project No.: _____
 S.I.S. No.: _____

LIFESTOR® Master Trak® Overhead Track Polymer Storage System

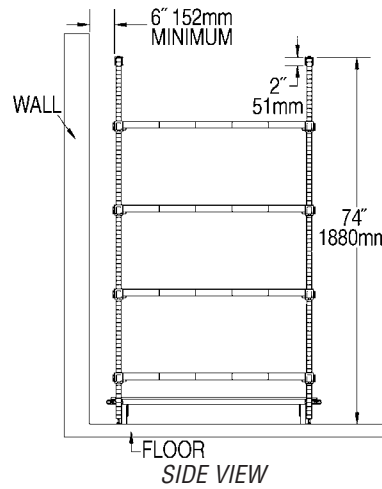
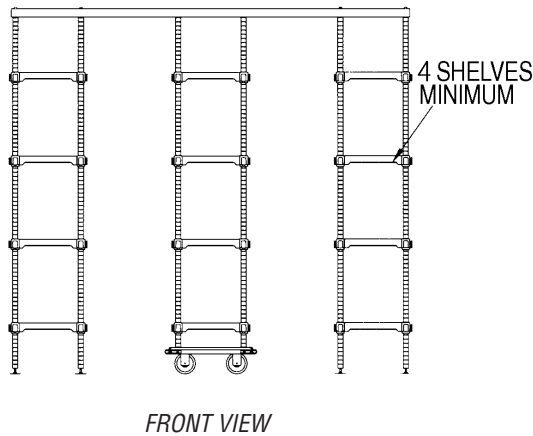
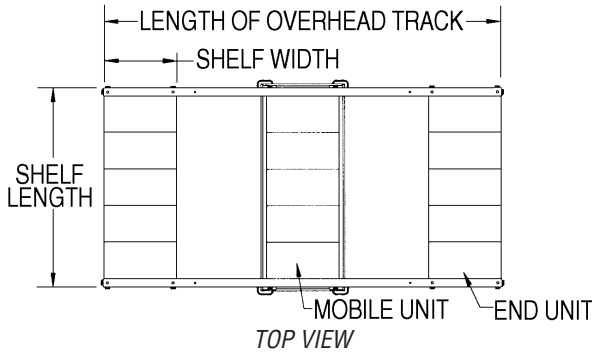

Note: shown with shelving (sold separately)

- Additional notes:**
- End-stationary units and mid-stationary units must have a minimum of four shelves.
 - Width of the end-stationary and mid-stationary units should be the same or larger than the width of mobile units.
 - Recommended aisle widths are 30"-36" (762-914mm). However, larger items may require an aisle width over 36" (914mm).
 - Mobile require stainless steel or zinc side braces, not plastic.
 - Maximum weight capacity of 300 lbs. (136.1 kg) per mobile unit.

Stationary Unit

model #	post height		weight	
	in.	mm	lbs.	kg
LEP74-S	74"	1880	17	7.7

Mobile Unit Kits

model #	dolly frame width x length		overall * width x length		weight	
	in.	mm	in.	mm	lbs.	kg
LMUK1836-S	18" x 36"	457 x 914	22" x 40"	559 x 1016	54	24.5
LMUK1842-S	18" x 42"	457 x 1067	22" x 46"	559 x 1169	57	25.9
LMUK1848-S	18" x 48"	457 x 1219	22" x 52"	559 x 1321	60	27.2
LMUK1854-S	18" x 54"	457 x 1372	22" x 58"	559 x 1473	62	28.1
LMUK1860-S	18" x 60"	457 x 1524	22" x 64"	559 x 1626	64	29.0
LMUK2336-S	23" x 36"	584 x 914	27" x 40"	686 x 1016	62	28.1
LMUK2342-S	23" x 42"	584 x 1067	27" x 46"	686 x 1169	63	28.6
LMUK2348-S	23" x 48"	584 x 1219	27" x 52"	686 x 1321	34	29.0
LMUK2354-S	23" x 54"	584 x 1372	27" x 58"	686 x 1473	66	29.9
LMUK2360-S	23" x 60"	584 x 1524	27" x 64"	686 x 1626	68	30.8

* Includes corner bumpers of dolly frame.

Overhead Track Units

model #	length		weight	
	ft.	mm	lbs.	kg
LOHT-6	6'	1829	18	8.2
LOHT-7	7'	2134	21	9.5
LOHT-8	8'	2438	24	10.9
LOHT-9	9'	2743	27	12.2
LOHT-10	10'	3043	30	13.6
LOHT-11	11'	3538	33	15.0
LOHT-12	12'	3658	36	16.3
LOHT-13	13'	3962	39	17.6
LOHT-14	14'	4267	42	19.1
LOHT-15	15'	4572	45	20.4
LOHT-16	16'	4877	48	21.8
LOHT-17	17'	5181	51	23.1
LOHT-18	18'	5486	54	24.5
LOHT-19	19'	5791	57	25.9
LOHT-20	20'	6096	60	27.2
LOHT-21	21'	6401	63	28.6

EAGLE GROUP

100 Industrial Boulevard, Clayton, DE 19938-8903 USA

Phone: 302-653-3000 • Fax: 302-653-2065

www.eaglegrp.com

Foodservice Division: Phone 800-441-8440

MHC/Retail Display Divisions: Phone 800-637-5100

Printed in U.S.A.
 ©2013 by Eagle Group

Rev. 10/13

Spec sheets available for viewing, printing or downloading from our online literature library at www.eaglegrp.com

Although every attempt has been made to ensure the accuracy of the information provided, we cannot be held responsible for typographical or printing errors. Information and specifications are subject to change without notice. Please confirm at time of order.