



Profit from the Eagle Advantage®

Specification Sheet

Short Form Specifications

Eagle Mobile Computer (Chrome / Stainless Steel) Workstation, model _____. Constructed of (chrome / stainless steel) wire shelves with patented Quadtruss® design. Furnished with keyboard drawer, 12"-wide cantilever shelf, wire undershelf, and wire worktop. (Chrome / stainless steel) tubular posts mounted on 5" swivel casters (two with brake).



mobile computer workstation shown with optional mouse shelf

Options / Accessories

- Mouse shelf
- 2 1/2" swivel decorative casters
- 4" swivel decorative casters
- Channel frame for rigid casters
- Aluminum split sleeves
- Anti-static drag chain
- Plastic shelf markers (3"-19" long)

EAGLE GROUP

100 Industrial Boulevard, Clayton, DE 19938-8903 USA

Phone: 302-653-3000 • Fax: 302-653-2065

www.eaglegrp.com

Foodservice Division: Phone 800-441-8440

MHC/Retail Display Divisions: Phone 800-637-5100

For custom configuration or fabrication needs, contact our SpecFAB® Division.

Phone: 302-653-3000 • Fax: 302-653-3091 • e-mail: specfab@eaglegrp.com

Item No.:	_____
Project No.:	_____
S.I.S. No.:	_____

Mobile Computer Workstations

MODELS:

- | | | |
|--------------------------------------|--------------------------------------|-------------------------------|
| <input type="checkbox"/> MCWS2424C | <input type="checkbox"/> MCWS2424S | <input type="checkbox"/> MS-C |
| <input type="checkbox"/> MCWS2424C-P | <input type="checkbox"/> MCWS2424S-P | |
| <input type="checkbox"/> MCWS3030C | <input type="checkbox"/> MCWS3030S | |
| <input type="checkbox"/> MCWS3030C-P | <input type="checkbox"/> MCWS3030S-P | |

Design and Construction Features

- Features include the following:
 - Two 48" (1219mm) rear posts;
 - Two 33" (838mm) front posts;
 - 5"-diameter swivel casters with resilient or polyurethane tread, two with brake.
 - One 12" (305mm)-wide wire cantilever shelf;
 - One full-length wire undershelf;
 - One wire tabletop;
 - One keyboard drawer;
 - One 3-sided frame.
- All wire shelves feature patented QuadTruss® design (patent #5,390,803).
- 38 3/4" (975mm) working height.
- 53 3/4" (1356mm) overall height.
- Available in chrome or stainless steel.
- Shipped knocked-down.

AUTOQUOTES



EG01.04 Rev. 04/12

Spec sheets available for viewing, printing or downloading from our online literature library at www.eaglegrp.com

Eagle Foodservice Equipment, Eagle MHC, SpecFAB®, and Retail Display are divisions of Eagle Group. ©2012 by the Eagle Group



Profit from the Eagle Advantage®

Item No.: _____
 Project No.: _____
 S.I.S. No.: _____

Mobile Computer Workstations

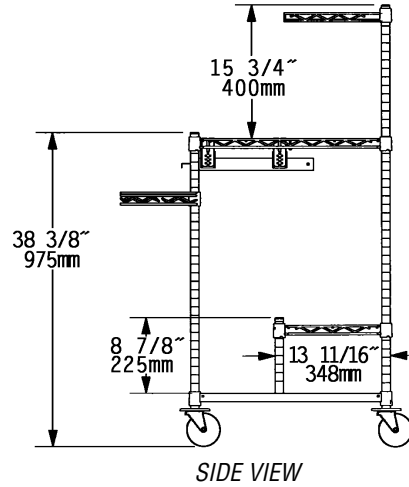
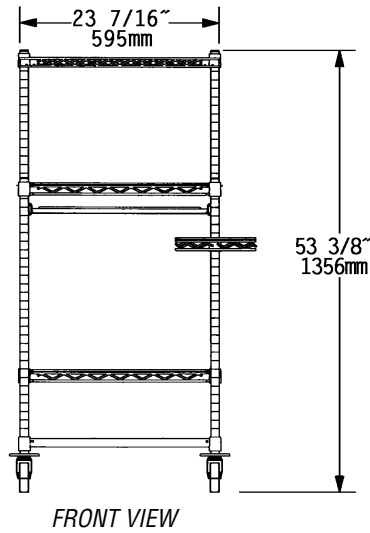
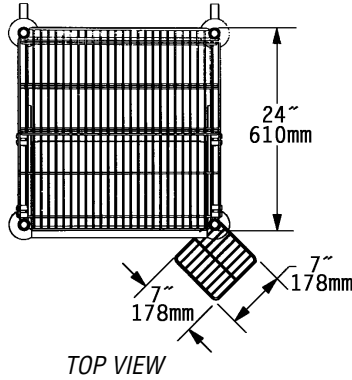

(note: #MCWS2424C shown)

w/Resilient-Tread Casters

w/Polyurethane-Tread Casters

chrome model #	stainless steel model #	chrome model #	stainless steel model #	tabletop width x length		undershelf width x length		weight	
				in.	mm	in.	mm	lbs.	kg
MCWS2424C	MCWS2424S	MCWS2424C-P	MCWS2424S-P	24"	610	24"	610	40	18.1
MCWS3030C	MCWS3030S	MCWS3030C-P	MCWS3030S-P	30"	762	30"	762	56	25.4

Optional Mouse Shelf

model #	width		length		weight	
	in.	mm	in.	mm	lbs.	kg
MS-C	7"	178	7"	178	2.0	0.9



optional mouse shelf

EAGLE GROUP

100 Industrial Boulevard, Clayton, DE 19938-8903 USA

Phone: 302-653-3000 • Fax: 302-653-2065

www.eaglegrp.com

Foodservice Division: Phone 800-441-8440

MHC/Retail Display Divisions: Phone 800-637-5100

Printed in U.S.A.
 ©2012 by Eagle Group

Rev. 04/12

Spec sheets available for viewing, printing or downloading from our online literature library at www.eaglegrp.com

Although every attempt has been made to ensure the accuracy of the information provided, we cannot be held responsible for typographical or printing errors. Information and specifications are subject to change without notice. Please confirm at time of order.